

# AnyWireASLINK System Product Guide

ASLINKSENSOR [Laser Spot, Transmissive Type]

## BS-L0117-PC-SET

### ■ Note on use

For setting addresses and other parameters, ARW-04 (Ver. 04-1.01 or later version) is required. Prepare the Address Writer separately.

### [Notes on Safety]

Precautions that must be observed in order to use this system safely are indicated as shown below. You must observe these precautions.

**WARNING** A WARNING indicates a potentially hazardous situation which, if not handled correctly, could result in death or serious injury.

**CAUTION** A CAUTION indicates a potentially hazardous situation which, if not handled correctly, may result in personal injury or property damage.

**WARNING**

- System Safety  
This system is intended for general industrial applications. It does not have functions for supporting applications requiring higher levels of safety such as safety-related devices or accident prevention systems. The product must not be used for these purposes.
- Always turn off the power in installing or replacing the system.
- Prolonged continuous flow of a rated load current or higher or a transit current due to load short-circuit, etc., in the hybrid unit including the output unit and the output circuit may result in smoking or firing. An external safety device such as a fuse must be installed.

**CAUTION**

- System power supply  
Use a stable, 24V DC power supply. Use of an unstable power supply may cause problems with the system.
- Separately route high-voltage and power cables  
Although the AnyWireASLINK has a high noise margin, install the transmission line and I/O cables away from high-voltage and power cables.
- Connectors and terminals
  - Consider the length and securing method of cables so that the cables and connectors would not be subjected to any stress and, even if they are under stress, they would not become loose.
  - Make sure to prevent any metal objects from getting inside the connectors or the terminal blocks.
  - Short-circuits caused by metal objects or mis-wiring are likely to damage the device.
- Do not impose any external loads on the units. Doing so may cause a failure.
- Do not disconnect or reconnect between the transmission line and slave units when the transmission line is active. A malfunction may occur.
- Use the AnyWireASLINK within the range of the specifications and conditions shown below.

### [Warranty]

#### ■ Warranty period

The warranty on the delivered Product shall continue to be effective for one (1) year after the delivery thereof to a location as designated by the original owner.

#### ■ Scope of warranty

Should a defect occur in any part of the Product during the foregoing warranty period when it is used normally in accordance with the specifications described in this Product Guide, the Company shall replace or repair the defect free of charge, except when it arises as a result of:

- [1] Misuse or abuse of the Product by the owner;
- [2] Fault caused by other than the delivered Product;
- [3] The unauthorized modification or repair of the Product by any person other than the Company's personnel;
- [4] Any unusual force of nature, disaster or other cause beyond the Company's control.

The term "warranty," as used herein, refers to the warranty applicable to the delivered product alone. The Company shall not be liable for consequential or incidental damages resulting from any malfunction.

#### ■ Repair at cost

After the expiration of the warranty period, the owner shall be responsible for all costs and expenses incurred for the troubleshooting and repair of the Product. Even during the warranty term, the Company shall repair any defects arising from causes other than within the scope of the warranty as specified above, at the owner's cost.

#### ■ Changes in the product specifications and the descriptions in the manual

The descriptions in this manual may be subject to change without notice.

### [Laser Safety]

#### ■ Warning label

An explanation label is provided on the side face of this sensor according to JIS C 6802:2014 and IEC 60825-1:2007.



Do not look directly into the laser beam because it is dangerous. Provide a consideration to prevent the reflective beam from harming human eyes by terminating the path of laser beam. If the sensor is used with the laser beam path open, pay attention not to let the beam hitting human eyes directly by avoiding eye level for the laser beam path.

### [Type]

AnyWireASLINK sensor: Laser spot, transmissive type, bit operation

#### ■ Kit model

(Individual models)

BS-L0117-PC-SET	BS-L0117-1KP (Transmitter)	Output 1 point
	BS-L0117-1KC (Receiver)	Input 1 point

### [Functions]

Model	ASLINKSENSOR 2-wire type (non-isolated)
Detection method	Transmissive type
Description	Remote address change*1
	Sensitivity adjustment (threshold)
	Hysteresis
	Alarm determination level
	Alarm determination time
	Light ON/Dark ON
	Operation mode
	Sensing level mode switching
	Delay timer
	One shot
	Laser beam ON/OFF
	Mutual interference prevention
Optical axis check indication	

\*1 To use this function, the master unit compatible with each function is required. For details, refer to this manual together with the manual for the master unit.

#### ■ Detecting functions (Status details)

Description	Slave unit voltage drop	I/O disconnection	I/O short-circuit	Sensing level drop	I/O power supply drop	Laser output operation error
	○	×	×	○	×	○

\*2 It depends on lot No. whether this function is available or not.

### [Function Compatibility by Lot No.]

This unit has undergone addition of functions and change of specifications according to version upgrading. Available functions and specifications of the unit vary depending on lot No.

Function/specification	Lot No.
Detection of laser output operation error	Available with lot No. that indicates year and month digits of "20D" or later.

#### ■ How to check

Lot No. is indicated on the lot label.

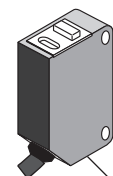

Bottom of this unit

Example:

# Lot No. 19E

May 2019

## [Included in the Package]

BS-L0117-1KP (Transmitter)	This product ... 1
BS-L0117-1KC (Receiver)	This product ... 1

\* Mounting fitting should be purchased separately as required.

## [Name of Each Part]

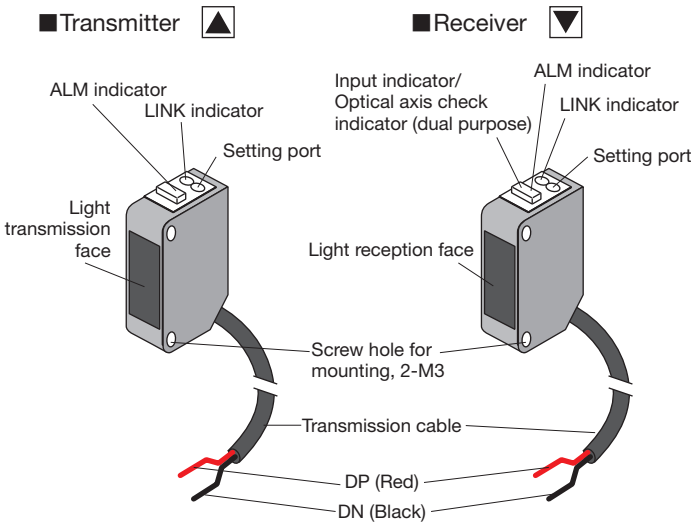

## [How to Connect AnyWireASLINK]

The AnyWireASLINK can employ a two-wire or four-wire terminal selectively depending on the load current. If the load current is small, using a two-wire (non-isolated) terminal allows for achieving simplified wiring without local power supply. In the case of prioritizing the sites of concentrated loads and/or the number of connections, hybridization with a four-wire (isolated) terminal, which supports local power supply, is also possible. Make sure to use a four-wire (isolated) terminal in the case of input and load driving using an external power supply.

## [System Configuration Example]

### ■ Connection with 2-wire (non-isolated) terminals only

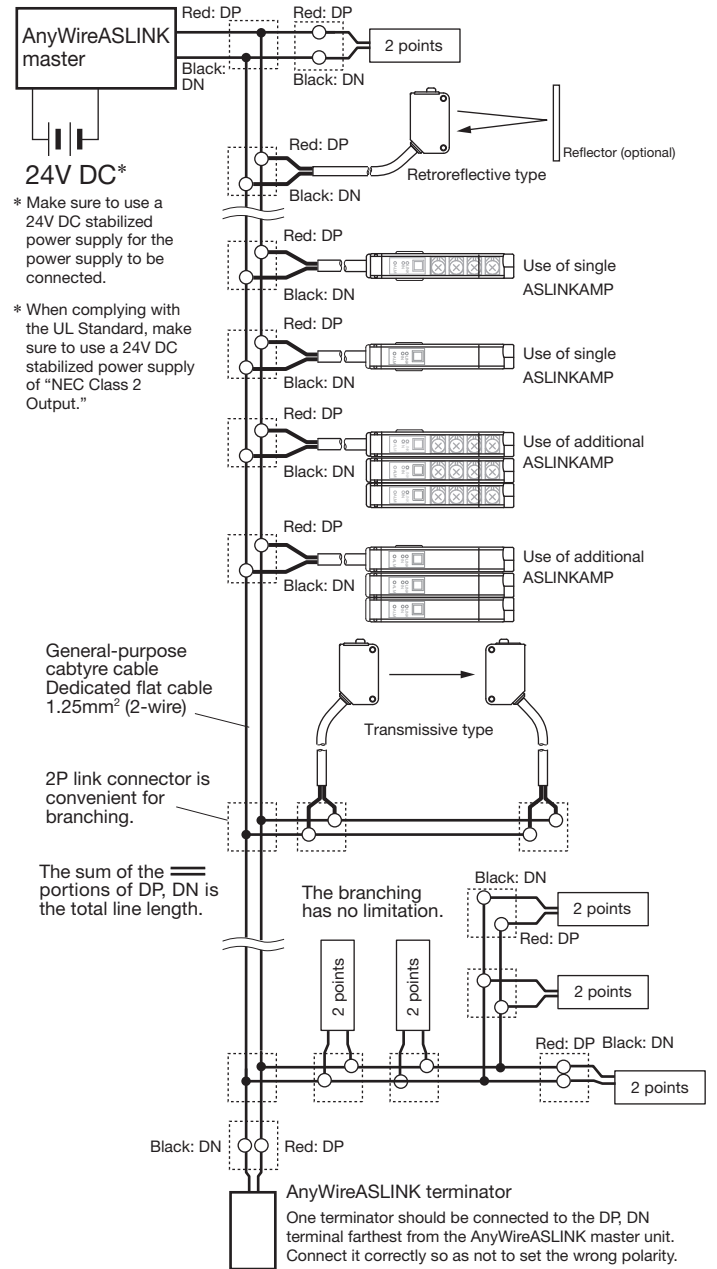

### ■ Relationship between the size and length of the transmission line and the supply current (Table 1)

Size of the transmission line (DP, DN)	Supply current on the transmission line (DP, DN)		
	Total length: 50m or less	Total length: Over 50m, no longer than 100m	Total length: Over 100m, no longer than 200m
1.25mm <sup>2</sup>	MAX 2A	MAX 1A	MAX 0.5A
0.75mm <sup>2</sup>	MAX 1.2A	MAX 0.6A	MAX 0.3A
0.5mm <sup>2</sup>	MAX 0.8A	MAX 0.4A	MAX 0.2A



- Refer to Table 1 so that the size and length of the transmission line and the allowable supply current lie within an appropriate range.
- Connect the same symbols (DP, DN) correctly between the AnyWireASLINK master unit and each device.
- The branching length or branch number has no limitation.
- Include the length of the cable provided with the terminal in the "total line length."
- Connect the terminator (with polarity) on the transmission line terminal farthest from the AnyWireASLINK master unit.

■ Example of mixed installation with 2-wire (non-isolated) and 4-wire (isolated) terminals

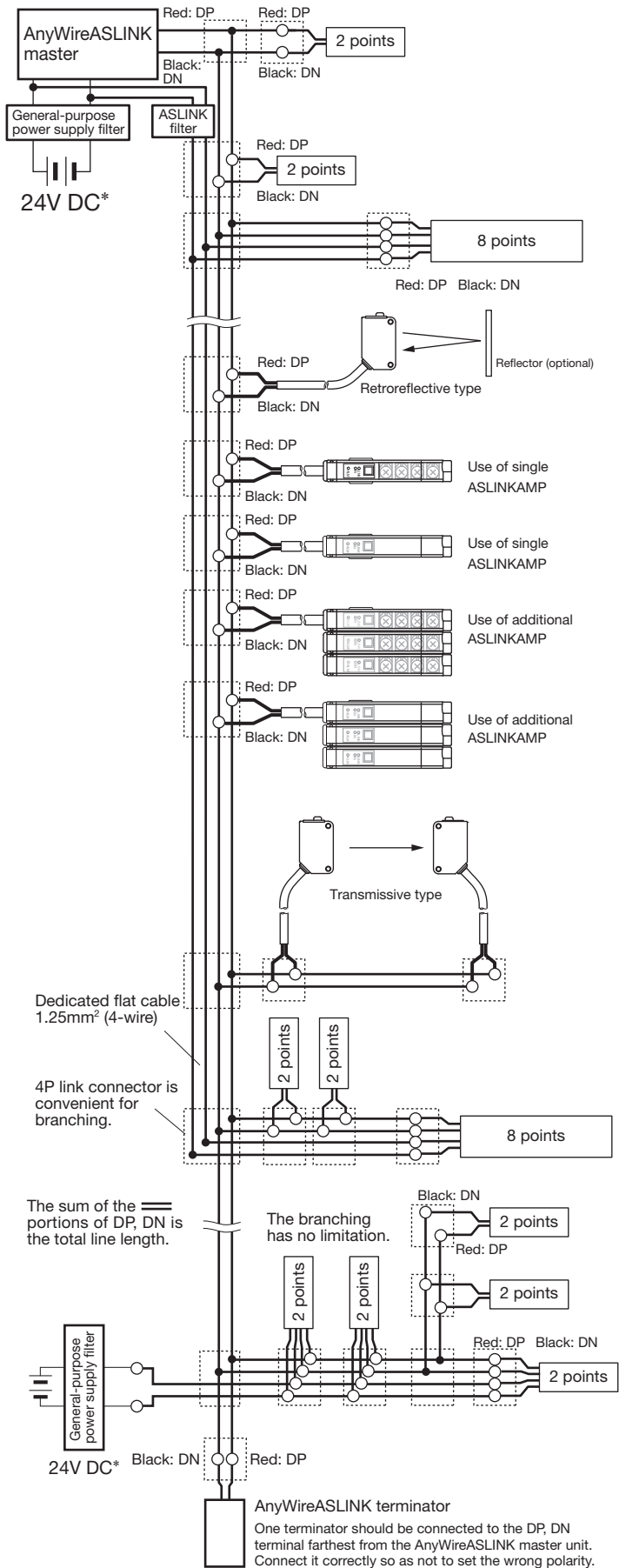

The sum of the portions of DP, DN is the total line length.

The branching has no limitation.

**CAUTION** To connect loads (e.g. I/O ports) that are controlled with a power supply other than the one used for the AnyWireASLINK system, always use a 4-wire (isolated) terminal. Otherwise, malfunction may be caused.

■ [Notes on Combined Use of 4-Wire (Isolated) Terminal]

If the total length of the sections where all the DP, DN, 24V, and 0V lines run in parallel in the power supply system is more than 50m, connect an ASLINK filter (Type ANF-01) or a filter manufactured by COSEL Co., Ltd. (Type EAC-06-472) in series to the 24V and 0V lines at a position where these four lines start running in parallel.

This will improve noise resistance, suppress the adverse effects of crosstalk caused by transmitted signals, and stabilize signals. The above filters must be inserted regardless of whether power is supplied to all terminals collectively from the power supply for the master or power is supplied to each terminal individually from their local power supply.

Insert the "ASLINK filter [Type ANF-01]" regardless of installation method and distance when complying with CE Standard.

■ Filter allowable current

Product	Type	Allowable power current
ASLINK filter	ANF-01	MAX 5A/24V DC
Filter of COSEL Co., Ltd.	EAC-06-472	MAX 6A/24V DC

■ AnyWire Type: ANF-01 Connection example

① Power supply to the entire system

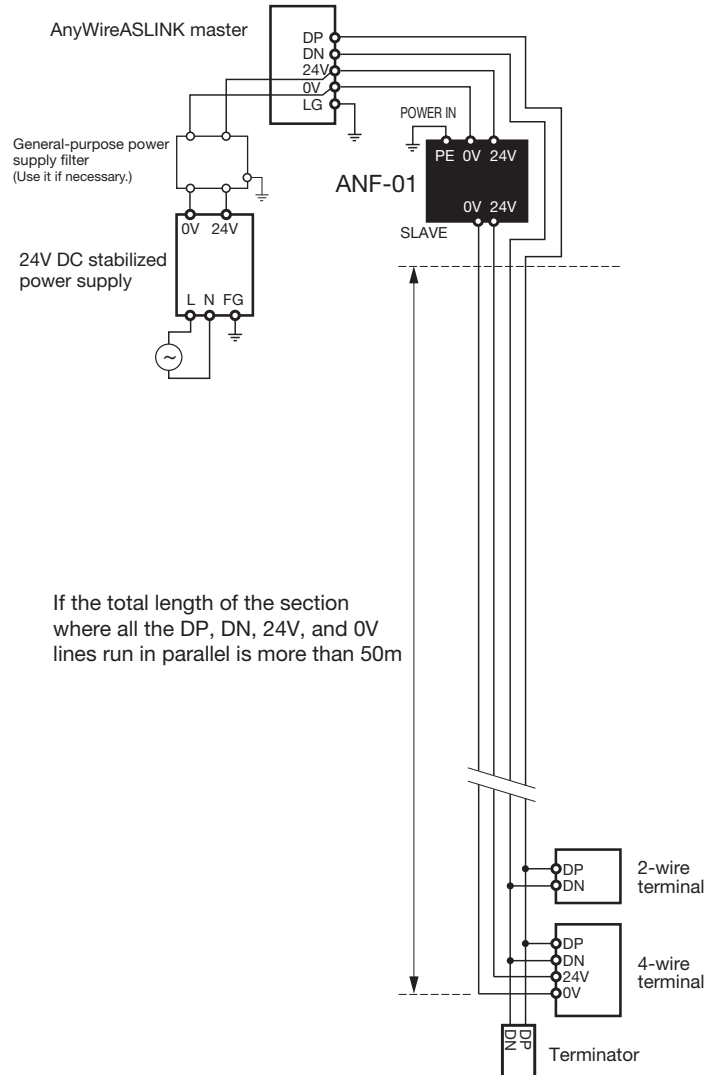

If the total length of the section where all the DP, DN, 24V, and 0V lines run in parallel is more than 50m

② Local power supply/branching

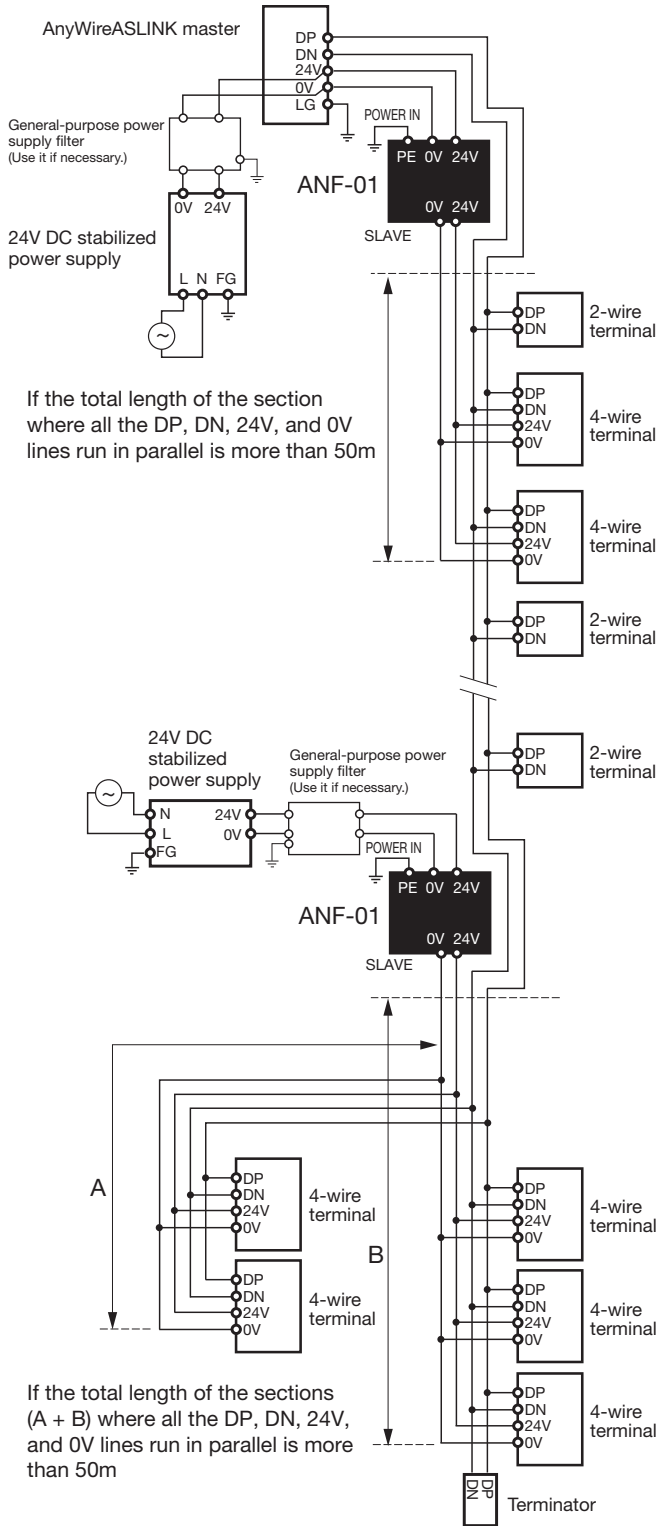

■ Filter representation in the drawing

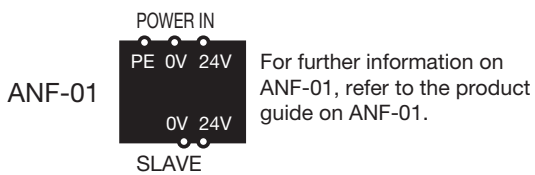

■ COSEL Co., Ltd. Type: EAC-06-472 Connection example

① Power supply to the entire system

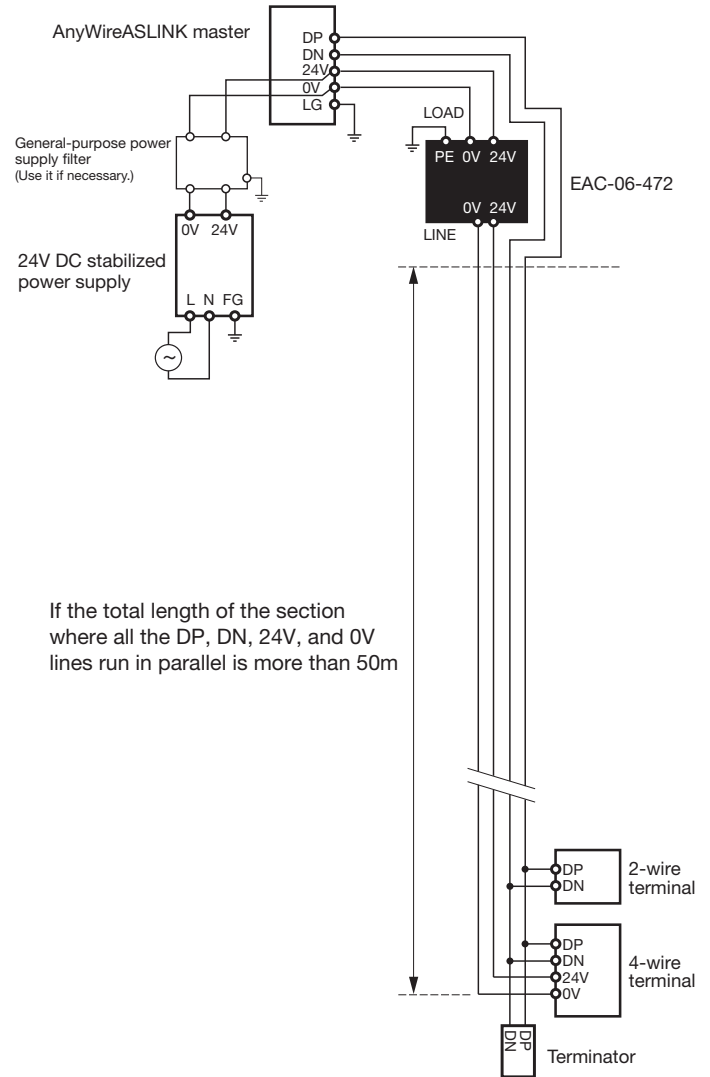

② Local power supply/branching

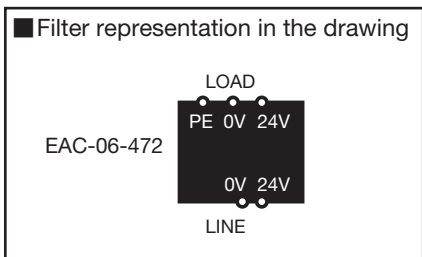
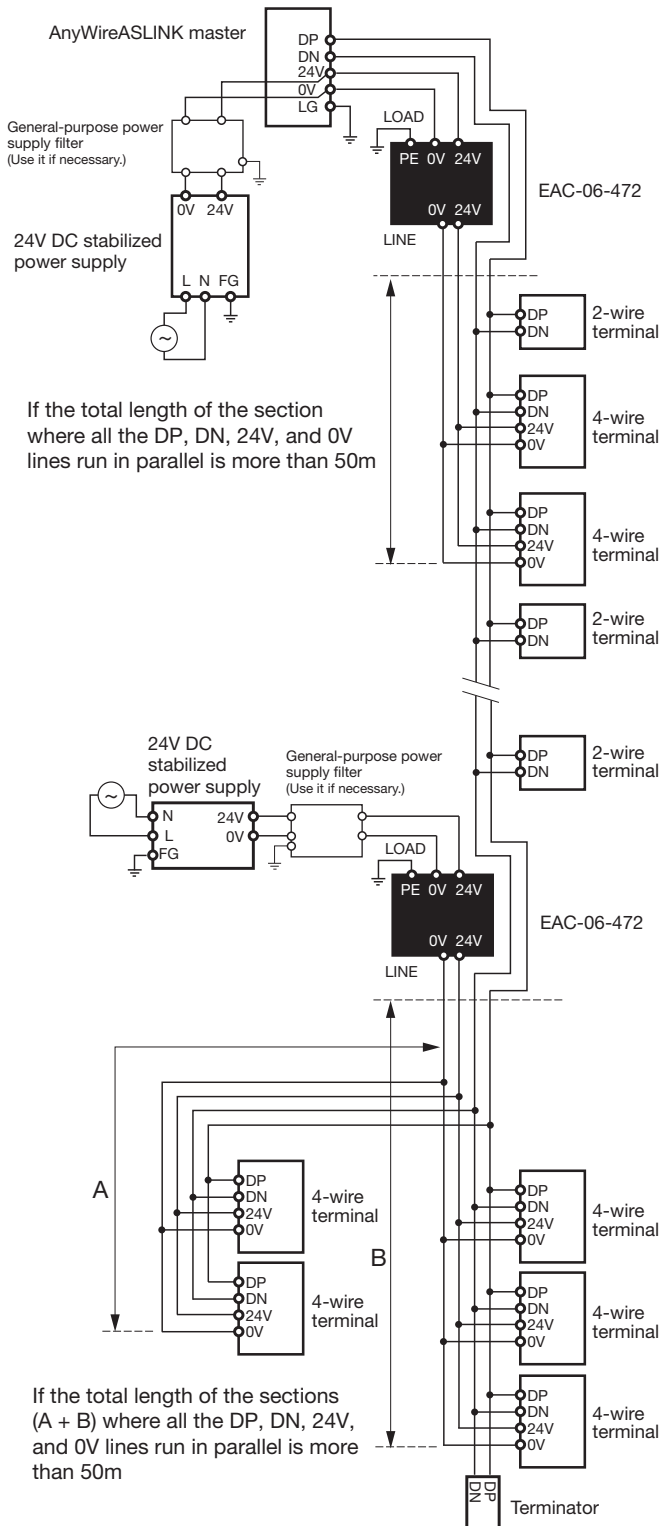

[Connection Method]

Connect the transmission line included in the master unit to the transmission line of the AnyWireASLINK master unit. Make sure that connections of the positive and negative polarities are correct.

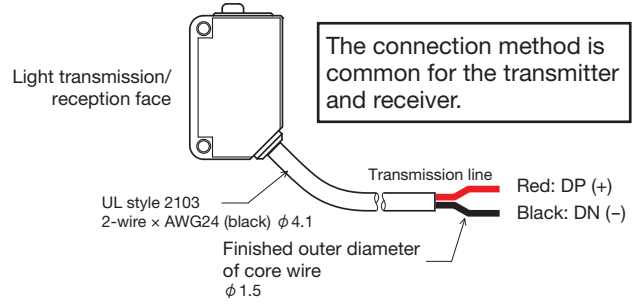

■ Example of fitting the LP connector at the end of transmission line

Applicable LP connector: LP2-PWH-10P

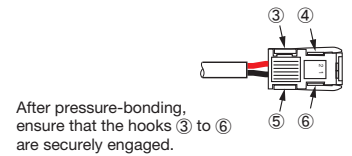
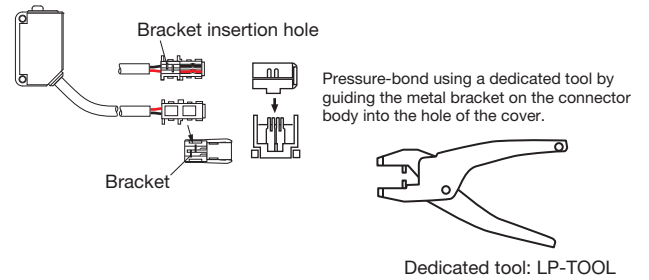
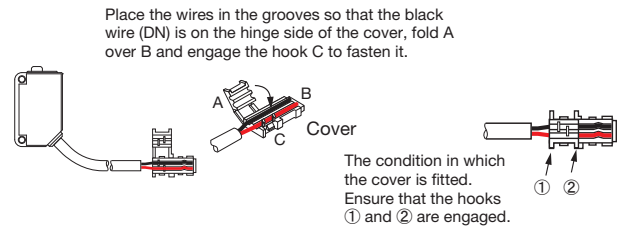

## [Installation Example]

The installation method is common for the transmitter and receiver.

The bracket should be purchased separately.  
M3 screw tightening torque: 0.25N·m or less

### CAUTION

To secure the sensor, allow some extra length on the cable so that the cable and the connectors would not be subjected to any stress. Do not tighten the screws too tight. Doing so may cause a failure or optical axis deviation.

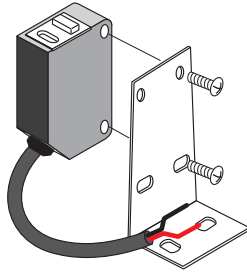

## [Installation Location]

- Locations where this product is not directly subject to vibration or shock
- Locations where this product is not exposed to dust and/or water continuously, even if it is waterproof
- Locations where this product is not directly exposed to conductors, such as metal chips or spatters
- Locations without condensation
- Locations where the atmosphere is free of corrosive gases, flammable gases, and sulfur
- Locations far from high-voltage or high-current cables
- Locations far from servos, inverters, and other cables and controllers that generate high-frequency noise
- Locations where this product is not directly exposed to the sunlight

### CAUTION

Be careful in installing the sensors as the heights of transmission and reception areas are different. Install them by visually confirming that the laser beam spot is on the reception area or by adjusting the optical axis while monitoring the sensing level.

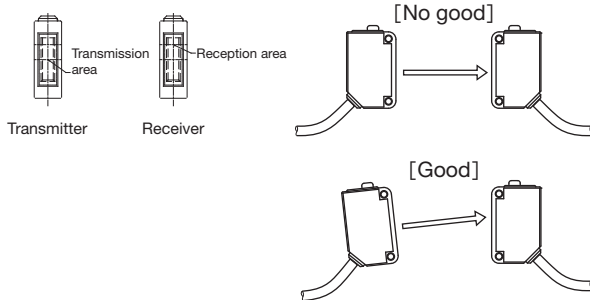

## [Notes on the Use]

- This unit should be used by connecting it with the AnyWireASLINK transmission line. It will not work if it is connected directly to an I/O card for a PLC.
- Use it in an appropriate voltage range.
- The transmission line attached to ASLINKSENSOR should be counted in the determination of the total length.

## [Various Settings]

Address setting

Teaching

Parameter setting

### Common procedure for address writer operation

Use the address writer with the sensor connected to the AnyWireASLINK master unit.  
An address writer ARW-04 (Ver. 04-1.01 or later) is required for the operation.  
For further information on the operation, refer to the product guide for the address writer.

1. Connect the terminal to the AnyWireASLINK master unit.  
With the transmission signal (DP, DN) being connected, set parameters with the address writer.

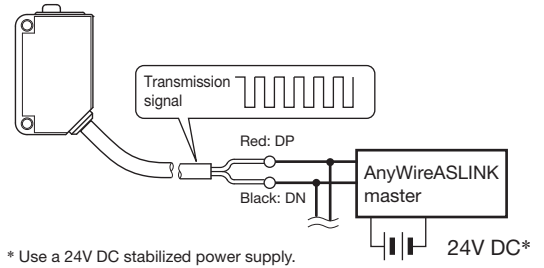

2. All terminals require settings.  
Perform the settings with the address writer pointed toward the setting port on the transmitter/receiver.  
(Hold the light emitting/receiving part as close as possible to the setting port.)

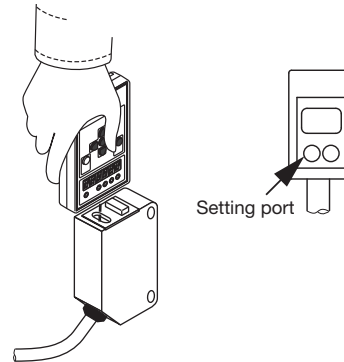

### Address setting

For address numbers, specify the leading number of the transmission frames to be allocated to the terminal.  
The address numbers of this unit are set between 0 and 254.

### CAUTION

The factory setting of the terminal is "255," which means no setting.  
If the address number is set to 255, the terminal does not perform I/O operations.  
Before using the terminal, be sure to set an address number between 0 and 254.

\* The same address number must be set for a pair of transmitter and receiver.

Teaching (on the receiver only)

Save the condition with and without a workpiece in the ASLINKSENSOR.

The setting procedure should be conducted with a workpiece to be actually used.  
To select the "0-100%" mode for the light receiving level indication setting (equipment parameter 8), be sure to conduct teaching.

[SET ON setting]

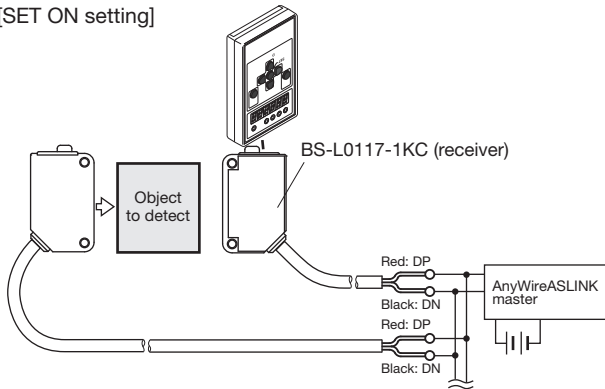

[SET OFF setting]

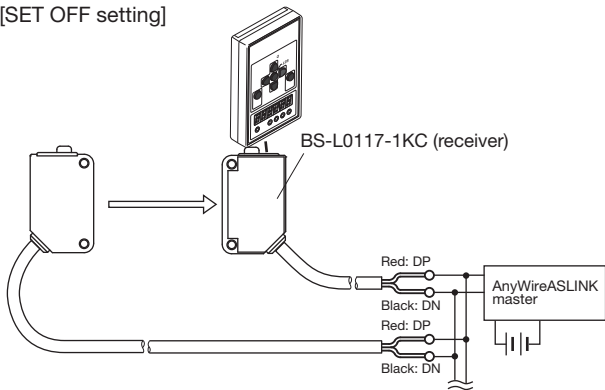



[Automatic setting for teaching]

If you conduct teaching when "AD value indication" is selected for the light receiving level indication setting (equipment parameter 8), "threshold," "hysteresis," "alarm Hi" and "alarm Lo" values will be automatically calculated and set at the following ratio, based on the difference in AD values between SET ON status (workpiece is present) and SET OFF status (no workpiece).

\* When the "0-100%" mode is selected for light receiving level indication setting (equipment parameter 8), the automatic setting function for teaching is disabled.

Threshold	50%
Hysteresis	5%
Alarm Hi	80%
Alarm Lo	20%

Example)

- ① SET ON  AD value for workpiece present status is "0."
- ② SET OFF  AD value for workpiece absent status is "980."

With the difference "980" in AD values between SET ON status and SET OFF status defined as the reference (100%), the following parameters will be automatically set.  
Threshold (Equipment parameter 1): 490 (50%)  
Hysteresis (Equipment parameter 2): 49 (5%)  
Alarm Hi (Equipment parameter 3): 784 (80%)  
Alarm Lo (Equipment parameter 4): 196 (20%)

Parameter setting

■ Threshold setting (receiver) [Equipment parameter 1]

This parameter determines the level of light to be received for detecting a workpiece.

Variable	Description
0-1023	AD value
0-100	0-100%

\* With the equipment parameter 8 setting of "0"

\* With the equipment parameter 8 setting of "1"

Factory setting: 50

■ Hysteresis setting (receiver) [Equipment parameter 2]

This parameter determines the light level required for the detection condition to change from ON to OFF.

Variable	Description
0-1023	AD value
0-100	0-100%

\* With the equipment parameter 8 setting of "0"

\* With the equipment parameter 8 setting of "1"

Factory setting: 10

■ Alarm Hi setting (receiver) [Equipment parameter 3]

This parameter determines the upper limit for issuing an alarm.  
\* Set the alarm level so that the relationship  $Hi > Lo$  will be satisfied.

Variable	Description
0-1023	AD value
0-100	0-100%

\* With the equipment parameter 8 setting of "0"

\* With the equipment parameter 8 setting of "1"

Factory setting: 0

■ Alarm Lo setting (receiver) [Equipment parameter 4]

This parameter determines the lower limit for issuing an alarm.  
\* Set the alarm level so that the relationship  $Hi > Lo$  will be satisfied.

Variable	Description
0-1023	AD value
0-100	0-100%

\* With the equipment parameter 8 setting of "0"

\* With the equipment parameter 8 setting of "1"

Factory setting: 0

■ Alarm monitoring time setting (receiver) [Equipment parameter 5]

This parameter determines the monitoring time of alarm determination.

Variable	Unit
3-255	100ms

Factory setting: 50

■ Light ON/Dark ON setting (receiver) [Equipment parameter 6]

This parameter determines Light ON or Dark ON.

Variable	Description
0	Dark ON
1	Light ON

Factory setting: 0

■ Operation mode setting (receiver) [Equipment parameter 7]

This parameter disables/enables the preventive maintenance function and optical axis check indication.

Variable	Description
0	Preventive maintenance function OFF, optical axis check indication OFF
1	Preventive maintenance function ON, optical axis check indication OFF
2	Preventive maintenance function OFF, optical axis check indication ON
3	Preventive maintenance function ON, optical axis check indication ON

Factory setting: 2

<Preventive maintenance function>

By enabling the preventive maintenance function, it is possible to detect the drop in the sensing level.  
The sensing level is determined to have dropped if the current sensing level remained within the range set with the alarm Hi (equipment parameter 3) and alarm Lo (equipment parameter 4) for a period set in the alarm monitoring time (equipment parameter 5).

(Example)

With the settings of:  
Alarm Hi (equipment parameter 3) : 80  
Alarm Lo (equipment parameter 4) : 20  
Alarm monitoring time (equipment parameter 5): 50

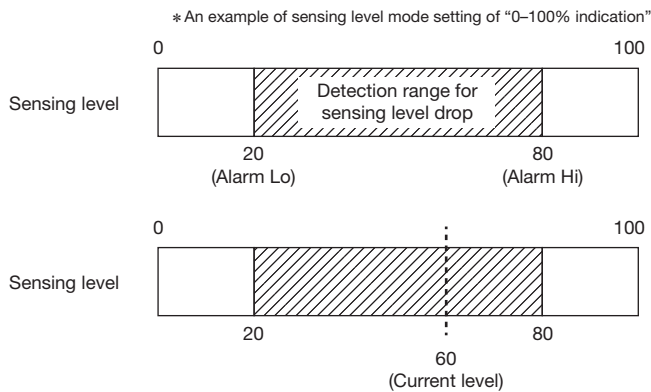

If this condition continues for 5000ms (equipment parameter 5: 50 × 100ms), it is detected as a drop in the sensing level and the user is notified with the ALM indicator on the unit and the alarm information is sent to the status detail area\*1 on the master unit.

\*1 This can be used on the master unit having the status detail area. For details, refer to the manual for the master unit.

<Optical axis check indication>

By enabling the optical axis check indication, the "IN/optical axis check indicator" blinks to notify the user if the current sensing level is near the threshold and the determination of ON/OFF condition is unstable.

\*The ON/OFF operation continues according to the threshold setting with the indication of unstable operation.

■ Sensing level mode setting (receiver) [Equipment parameter 8]

This parameter determines the sensing level. Based on this setting, equipment parameters 1, 2, 3, 4 and the sensing level will be automatically set to AD value or a value in the range of 0 to 100%.

Variable	Description
0	AD value indication (0-1023 Digit)
1	0-100% indication

Factory setting: 0

\*Once the setting was modified by writing parameters from the host, the values of equipment parameters 1, 2, 3 and 4 will not be converted automatically.

■ ON delay setting (receiver) [Equipment parameter 10]

This parameter determines the ON delay time.

Variable	Unit
0-999	100ms

Factory setting: 0

■ OFF delay setting (receiver) [Equipment parameter 11]

This parameter determines the OFF delay time.

Variable	Unit
0-999	100ms

Factory setting: 0

■ One Shot setting (receiver) [Equipment parameter 12]

This parameter determines the One Shot time.

Variable	Unit
0-999	100ms

Factory setting: 0

■ Laser beam ON/OFF setting (transmitter) [Equipment parameter 17]

The laser beam can be turned ON and OFF.

Variable	Description
0	Laser beam OFF
1	Laser beam ON
0→1	Laser output operation error clear*2

Factory setting: 1

\*2 Supported by products of Lot No. "20D" or later.

If the state shifts from laser beam OFF to ON, the laser output operation error is cleared and the laser beam will be turned ON again.

Equipment parameters [9], [13] through [16], [18] and [19] are system parameters. Do not change their settings.

[Data Configuration]

Address offset	n
Description	IN

\*n = Bit address number set in this unit

■ Sensing level

This unit sends the light reception level to the "sensing level area\*3" on the master unit.

Sensing level	Light reception level (16-bit binary data)
---------------	--

Sensing level mode (equipment parameter 8)  
indication in AD value: 0 to 1023 (0Hex to 3FFHex)  
Sensing level mode (equipment parameter 8)  
indication in 0-100%: 0 to 100 (0Hex to 64Hex)

\*3 This can be used on the master unit having the sensing level area. For details, refer to the manual for the master unit.

■ Status details

The contents of an alarm detected with this unit can be checked with the "status detail area\*4" on the master unit. A bit corresponding to the status detail area turns ON depending on the contents of the alarm.

Status detail area of the master unit

Status details	b15	b14	b13	b12	b11	b10	b9	b8	b7	b6	b5	b4	b3	b2	b1	b0
----------------	-----	-----	-----	-----	-----	-----	----	----	----	----	----	----	----	----	----	----

b0: Slave unit voltage drop (DP-DN-side voltage drop)  
b1: Sensing level drop  
b6: Laser output operation error\*5

\*4 This can be used on the master unit having the status detail area. For details, refer to the manual for the master unit.

\*5 Supported by products of Lot No. "20D" or later.



## [Concept of Interference Prevention]













The interference prevention function of this unit involves the address numbers of sensors. They are divided in groups of even number by dividing the number of transmission points set on the AnyWireASLINK master unit by 16. The interference prevention function works between sensors with address numbers of different groups.

Number of transmission points	Address				
512 points (256/256)	0-15	16-31	••••	224-239	240-254
256 points (128/128)	0-7	8-15	••••	112-119	120-127
128 points (64/64)	0-3	4-7	••••	56-59	60-63
64 points (32/32)	0, 1	2, 3	••••	28, 29	30, 31
Group	①	②	••••	⑮	⑯

[Example: 512 point mode, sensor at address 10]  
 Interference can be prevented with sensors of address numbers 16 to 254.  
 Interference cannot be prevented with sensors of address numbers 0 to 15.

\* The concept is the same for the interference prevention function between this unit and other ASLINKSENSOR (photoelectric) and ASLINKAMP (photoelectric, fiber) units.

## [Monitor Display]

LED name	Display status	Description
LINK (Green)	Lit 	Transmission signal error
	Flashing 	Transmission signal supplied properly
	Unlit 	No transmission signal
ALM (Red)	Lit 	Sensing level drop*1
	Flashing 	Slave unit voltage drop
	Flashing  Lit for 0.1 sec. ⇨ Unlit for 0.1 sec.	Laser output operation error*2
	Unlit 	Normal
LINK ALM	Alternate flashing LINK  ALM 	The master unit has detected that the unit ID (address) is either duplicated or unregistered
IN/ Optical axis check indication (Orange)	Lit 	ON
	Unlit 	OFF
	Flashing 	Unstable operation range*3

\*1 Enabled when the preventive maintenance function is ON.  
 \*2 Supported by products of Lot No. "20D" or later.  
 \*3 Enabled when the optical axis check indication is ON.  
 The ON/OFF operation takes place even during indication of the unstable operation range.

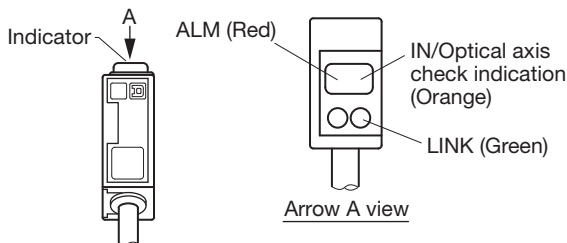

\* The "IN/optical axis check" indicator is not provided on the transmitter.

## [Troubleshooting]

If the following errors are indicated on the display window of ASLINKSENSOR, take the following actions.

LINK	IN	ALM	Cause	Remedy
○ Unlit	○ Unlit	○ Unlit	- The ASLINKSENSOR is not connected to the AnyWireASLINK system. - The AnyWireASLINK system is not turned on.	- Check if there is a disconnection between the ASLINKSENSOR and AnyWireASLINK system and, if there was a disconnection, restore the connection. - Check the power supply of AnyWireASLINK system and turn ON the power.
● Lit	○ Unlit	○ Unlit	- Connected directly to the 24-0V power supply.	- Reconnect the power to the AnyWireASLINK system.
◎ Flashing (alternates with a 0.5 sec. interval)	○ Unlit	◎ Flashing (alternates with a 0.5 sec. interval)	- The address of ASLINKSENSOR remains as "255" (factory setting). - The address of ASLINKSENSOR is duplicated.	- Assign an address other than 255. - Look for a unit that has the same error and assign an address different from the address of that unit.
—	—	◎ Flashing (Lit for 0.2 sec., unlit for 1.0 sec.)	- The voltage of internal power supply for the ASLINKSENSOR is low.	- Reduce the number of units connected to the same AnyWireASLINK system. - Reduce the length of transmission line between ASLINKSENSOR and the master unit.
—	—	◎ Flashing*4 (Lit for 0.1 sec., unlit for 0.1 sec.)	- A laser output operation error has been detected. - The transmission has stopped due to a laser output operation error. - There is a possibility that the unit has failed.	- Eliminate the cause and then reset the power or reset the error using the laser beam ON/OFF setting (equipment parameter 17), i.e. shifting the setting from "laser beam OFF" to "laser beam ON."
◎ Flashing	—	● Lit	- The sensing level is low.	- Check the condition of ASLINKSENSOR, adjust the optical axis and clean the transmission and reception faces.
◎ Flashing	◎ Flashing (0.1 sec. interval)	—	- The light reception level is in the unstable region.	- Adjust the optical axis and the threshold.

\*4 Supported by products of Lot No. "20D" or later.

If the following error is indicated on the address writer, take the following action.

Display	Cause	Remedy
[E-0303]	The parameter setting is incorrect.	Refer to the parameter correspondence table and correct the setting.

Should any of the following apply, take the following actions.

Symptom	Remedy
Detection cannot be made	- Are the angles of transmission and reception faces correct? → If the transmission and reception faces are not in line with each other, install the units properly. - Is the wiring correct? → Recheck the connection of ASLINKSENSOR transmission line. - Is there a power supply with a capacity appropriate for the AnyWireASLINK master and slave units and turned ON? → Check the power supply. - Are addresses set in the transmitter and receiver matched? → Set the same address for both the transmitter and receiver. - Has teaching been performed? → Perform teaching using a workpiece to be detected in the operation. - Is the sensor used in the specified detection range? → Use it within its rating.
Setting cannot be made with the address writer	- Is the wiring correct? → Recheck the connection of ASLINKSENSOR transmission line. - Is the power supplied to the AnyWireASLINK system? → Check the power supply. - Are the parameters set correctly? → Refer to the parameter correspondence table and correct the setting.

## [Equipment Parameters and Their Settings]

Parameter	Variable	Description	Factory setting
[1] Threshold	0-1023*1 (0-100%)	Light reception level for the detection	50
[2] Hysteresis	0-1023*1 (0-100%)	Change in the light reception level required for the detection status to change from ON to OFF	10
[3] Alarm Hi	0-1023*1 (0-100%)	Upper limit of light reception level for issuing an alarm	0
[4] Alarm Lo	0-1023*1 (0-100%)	Lower limit of light reception level for issuing an alarm	0
[5] Alarm monitoring time	3-255	Monitoring time of the light reception level for issuing an alarm (1 = 100ms)	50
[6] Light ON/ Dark ON	0	Dark ON	0
	1	Light ON	
[7] Operation mode	0	Preventive maintenance function OFF, optical axis check indication OFF	2
	1	Preventive maintenance function ON, optical axis check indication OFF	
	2	Preventive maintenance function OFF, optical axis check indication ON	
	3	Preventive maintenance function ON, optical axis check indication ON	
[8] Light reception level indication	0	AD value indication (0-1023 Digit)	0
	1	0-100% indication	
[10] ON Delay	0-999	ON delay time (1 = 100ms)	0
[11] OFF Delay	0-999	OFF delay time (1 = 100ms)	0
[12] One Shot	0-999	One Shot time (1 = 100ms)	0
[17] Laser beam ON	0	Laser beam OFF	1
	1	Laser beam ON	
	0→1	Laser output operation error clear*2	

\*1 The setting range depends on the equipment parameter 8 setting.

\*2 Supported by products of Lot No. "20D" or later.

## [Specifications]

### ■ General specifications

Operating ambient temperature/humidity	0 – +55°C, 10 – 90%RH (No condensation)
Storing ambient temperature/humidity	-25 – +70°C, 10 – 90%RH (No condensation)
Operating ambient illuminance	Brightness on the reception face equivalent to 3000 lx of incandescent light
Vibration resistance	Based on JIS B 3502 and IEC 61131-2
Shock resistance	Based on JIS B 3502 and IEC 61131-2
Operating atmosphere	No corrosive gas
Operating altitude*3	0 – 2000m
Pollution level*4	2 or less

\*3 Do not use or store AnyWireASLINK devices in an environment where the pressure exceeds the atmospheric pressure at an altitude of 0 meters. Doing so may result in malfunction.

\*4 "Pollution level" is an index that indicates the degree of occurrence of conductive substances in the environment where the device is used.

Pollution level 2 means the occurrence of only pollution by non-conductive substances.

In such an environment, however, electrical conduction could occur due to accidental condensation.

### ■ Transmission specifications

Service power supply voltage	24V DC +15% to -10% (21.6 to 27.6V DC) with a ripple of 0.5Vp-p or less
Transmission method	DC power supply superimposed total frame/cyclic method
Synchronization method	Frame/bit synchronization method
Transmission procedure	AnyWireASLINK protocol
Connection mode	Bus type (Multi-drop method, T-branch method, Tree branch method)
Number of connection points	512 max. (IN: 256, OUT: 256)
Number of connection units	Up to 128 units
RAS function	Detection of transmission line disconnection, transmission line short-circuit, and transmission power supply drop
	Detection of duplicated/unregistered ID

### ■ Individual specifications

Number of occupied points	BS-L0117-1KP (transmitter): Output 1 point BS-L0117-1KC (receiver): Input 1 point
Response time*5	1 – 2 cycles
Weight	33g (common for BS-L0117-1KP and BS-L0117-1KC)
Detection method	Transmissive
Detection distance	30m
Spot size*6	Approx. $\phi$ 2mm (at the distance of 2m)
Light source (illumination wavelength)	Red LD (655nm) JIS/IEC Class 1
Protective circuit	Short circuit protection of power supply, protection against reverse connection of power supply
Protection class	IP67
Current consumption	Transmitter 7mA, receiver 8mA

\*5 A time required for ON/OFF detection until transmission signal output.

To update data, 1-cycle transmission time is required in addition to the response time.

\*6 Reference value

## [Outside Dimensions]

Unit: mm

### ■ BS-L0117-1KP (Transmitter)

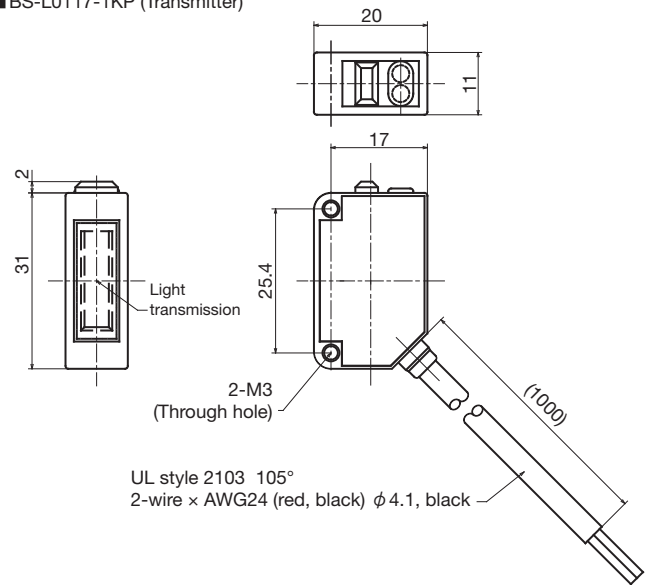

UL style 2103 105°

2-wire x AWG24 (red, black)  $\phi$  4.1, black

### ■ BS-L0117-1KC (Receiver)

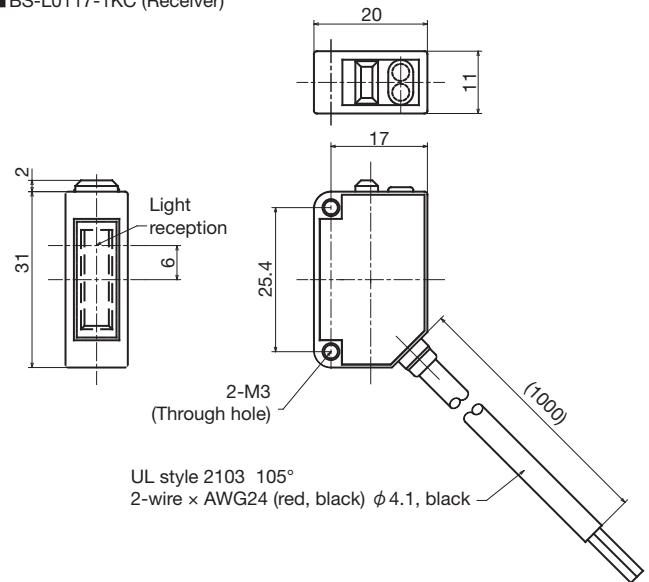

UL style 2103 105°

2-wire x AWG24 (red, black)  $\phi$  4.1, black

**【中国版RoHS指令】**

电子信息产品上所示标记是依据SJ/T11364-2006规定,按照电子信息产品污染控制标识要求制定。  
本产品的环保使用期限为10年,如果遵守产品说明书中的操作条件使用电子信息产品,不会发生因产品中的有害物质泄漏或突发异常而引起严重的环境污染、人身事故,或损坏财产等情况。

的产品中有害物质的名称及含量

部件名称	有害物质					
	铅 (Pb)	汞 (Hg)	镉 (Cd)	六价铬 [Cr(VI)]	多溴联苯 (PBB)	多溴二苯醚 (PBDE)
安装基板	×	○	○	○	○	○
框架	○	○	○	○	○	○

本表格依据SJ/T11364的规定编制。  
○：表示该有害物质在该部件所有均质材料中的含量均在GB/T26572规定的限量要求以下。  
×：表示该有害物质至少在该部件的某一均质材料中的含量超出GB/T26572规定的限量要求。



基于中国标准法的参考规格：GB/T15969.2

**[Address]**

**Anywire Anywire Corporation**

Headquarters :1 Babazusho, Nagaokakyo-shi, Kyoto 617-8550 JAPAN

Contact :Contact by mail info\_e@anywire.jp  
:Contact by website http://www.anywire.jp

Printed in Japan 2017,2019,2020 UMA-15857AF-EN