

# AnyWireASLINK System Product Guide

## ASLINKSENSOR [Diffuse Reflection Photoelectric Type (IP67)] **BS-H0317G-1K**

### ■ Note on use

For setting addresses and other parameters, ARW-04 (Ver. 04-1.01 or later version) is required. Prepare the Address Writer separately.

### [Notes on Safety]

Precautions that must be observed in order to use this system safely are indicated as shown below. You must observe these precautions.

**WARNING** A WARNING indicates a potentially hazardous situation which, if not handled correctly, could result in death or serious injury.

**CAUTION** A CAUTION indicates a potentially hazardous situation which, if not handled correctly, may result in personal injury or property damage.



- System Safety  
This system is intended for general industrial applications. It does not have functions for supporting applications requiring higher levels of safety such as safety-related devices or accident prevention systems. The product must not be used for these purposes.
- Always turn off the power in installing or replacing the system.
- Prolonged continuous flow of a rated load current or higher or a transit current due to load short-circuit, etc., in the hybrid unit including the output unit and the output circuit may result in smoking or firing. An external safety device such as a fuse must be installed.



- System power supply  
Use a stable, 24V DC power supply. Use of an unstable power supply may cause problems with the system.
- Separately route high-voltage and power cables  
Although the AnyWireASLINK has a high noise margin, install the transmission line and I/O cables away from high-voltage and power cables.
- Connectors and terminals
  - Consider the length and securing method of cables so that the cables and connectors would not be subjected to any stress and, even if they are under stress, they would not become loose.
  - Make sure to prevent any metal objects from getting inside the connectors or the terminal blocks.
  - Short-circuits caused by metal objects or mis-wiring are likely to damage the device.
- Do not impose any external loads on the units. Doing so may cause a failure.
- Do not disconnect or reconnect between the transmission line and slave units when the transmission line is active. A malfunction may occur.
- Use the AnyWireASLINK within the range of the specifications and conditions shown below.

### [Warranty]

#### ■ Warranty period

The warranty on the delivered Product shall continue to be effective for one (1) year after the delivery thereof to a location as designated by the original owner.

#### ■ Scope of warranty

Should a defect occur in any part of the Product during the foregoing warranty period when it is used normally in accordance with the specifications described in this Product Guide, the Company shall replace or repair the defect free of charge, except when it arises as a result of:

- [1] Misuse or abuse of the Product by the owner;
- [2] Fault caused by other than the delivered Product;
- [3] The unauthorized modification or repair of the Product by any person other than the Company's personnel;
- [4] Any unusual force of nature, disaster or other cause beyond the Company's control.

The term "warranty," as used herein, refers to the warranty applicable to the delivered product alone. The Company shall not be liable for consequential or incidental damages resulting from any malfunction.

#### ■ Repair at cost

After the expiration of the warranty period, the owner shall be responsible for all costs and expenses incurred for the troubleshooting and repair of the Product. Even during the warranty term, the Company shall repair any defects arising from causes other than within the scope of the warranty as specified above, at the owner's cost.

#### ■ Changes in the product specifications and the descriptions in the manual

The descriptions in this manual may be subject to change without notice.

### [Type]

AnyWireASLINK photoelectric sensor:  
Diffuse reflection photoelectric type, bit operation

BS-H0317G-1K

One light beam

### [Functions]

Model	ASLINKSENSOR 2-wire type (non-isolated)
Detection method	Diffuse reflection type
Features	Sensitivity adjustment (threshold)
	Hysteresis
	Alarm determination level
	Alarm determination time
	Light ON/Dark ON
	Operation mode
	Light reception level indication switching
	Delay timer
	One shot
	Sensing level drop
	Slave unit voltage drop
IP67 (Oil resistance under in-house standard)	

### [Included in the Package]

BS-H0317G-1K

This product ... 1

\* Mounting fitting should be purchased separately.

### [Name of Each Part]

#### ■ Diffuse reflection type

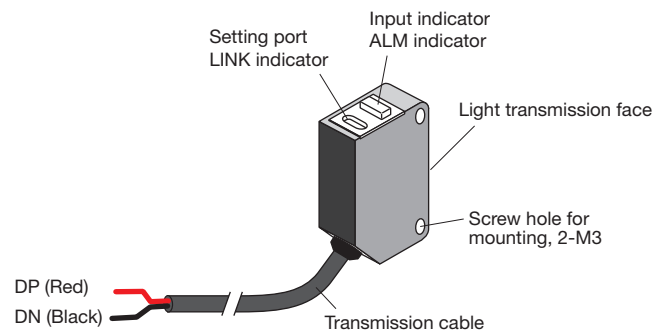

## [How to Connect AnyWireASLINK]

The AnyWireASLINK can employ a two-wire or four-wire terminal selectively depending on the load current. If the load current is small, using a two-wire (non-isolated) terminal allows for achieving simplified wiring without local power supply.

In the case of prioritizing the sites of concentrated loads and/or the number of connections, hybridization with a four-wire (isolated) terminal, which supports local power supply, is also possible.

Make sure to use a four-wire (isolated) terminal in the case of input and load driving using an external power supply.

## [System Configuration Example]

### ■ Connection with 2-wire (non-isolated) terminals only

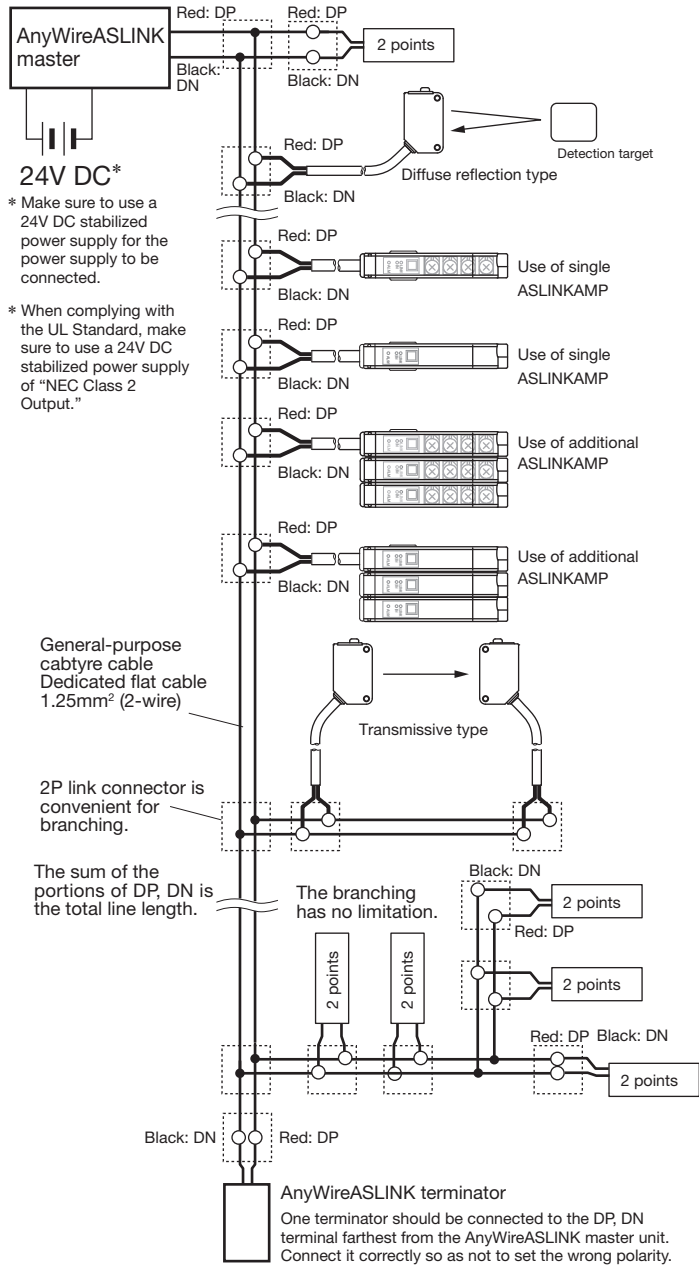

### ■ Relationship between the size and length of the transmission line and the supply current (Table 1)

Size of the transmission line (DP, DN)	Supply current on the transmission line (DP, DN)		
	Total length: 50m or less	Total length: Over 50m, no longer than 100m	Total length: Over 100m, no longer than 200m
1.25mm <sup>2</sup>	MAX 2A	MAX 1A	MAX 0.5A
0.75mm <sup>2</sup>	MAX 1.2A	MAX 0.6A	MAX 0.3A
0.5mm <sup>2</sup>	MAX 0.8A	MAX 0.4A	MAX 0.2A



- Refer to Table 1 so that the size and length of the transmission line and the allowable supply current lie within an appropriate range.

- Connect the same symbols (DP, DN) correctly between the AnyWireASLINK master unit and each device.
- The branching length or branch number has no limitation.
- Include the length of the cable provided with the terminal in the "total line length."
- Connect the terminator (with polarity) on the transmission line terminal farthest from the AnyWireASLINK master unit.

### ■ Example of mixed installation with 2-wire (non-isolated) and 4-wire (isolated) terminals

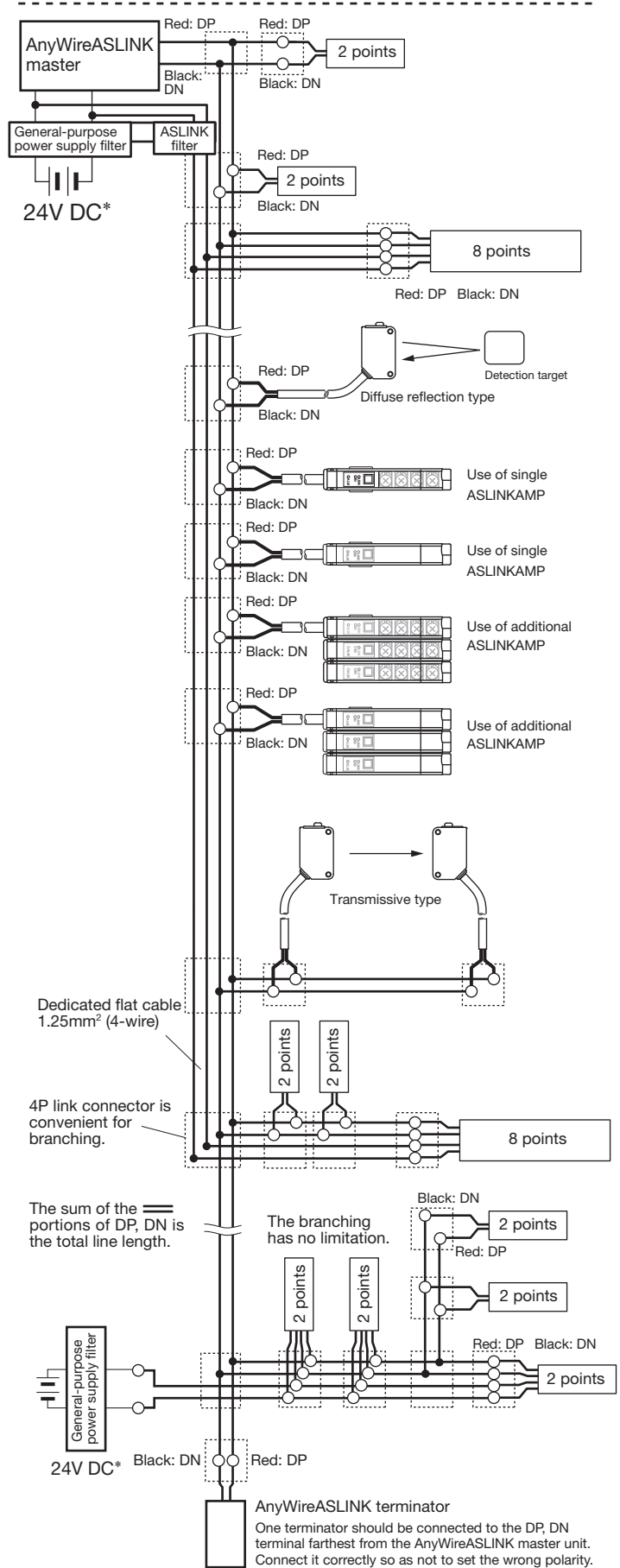

To connect loads (e.g. I/O ports) that are controlled with a power supply other than the one used for the AnyWireASLINK system, always use a 4-wire (isolated) terminal. Otherwise, malfunction may be caused.

**[Notes on Combined Use of 4-Wire (Isolated) Terminal]**

If the total length of the sections where all the DP, DN, 24V, and 0V lines run in parallel in the power supply system is more than 50m, connect an ASLINK filter (Type ANF-01) or a filter manufactured by COSEL Co., Ltd. (Type EAC-06-472) in series to the 24V and 0V lines at a position where these four lines start running in parallel.

This will improve noise resistance, suppress the adverse effects of crosstalk caused by transmitted signals, and stabilize signals. The above filters must be inserted regardless of whether power is supplied to all terminals collectively from the power supply for the master or power is supplied to each terminal individually from their local power supply.

Insert the "ASLINK filter [Type ANF-01]" regardless of installation method and distance when complying with CE Standard.

**Filter allowable current**

Product	Type	Allowable power current
ASLINK filter	ANF-01	MAX 5A/24V DC
Filter of COSEL Co., Ltd.	EAC-06-472	MAX 6A/24V DC

**AnyWire Type: ANF-01 Connection example**

① Power supply to the entire system

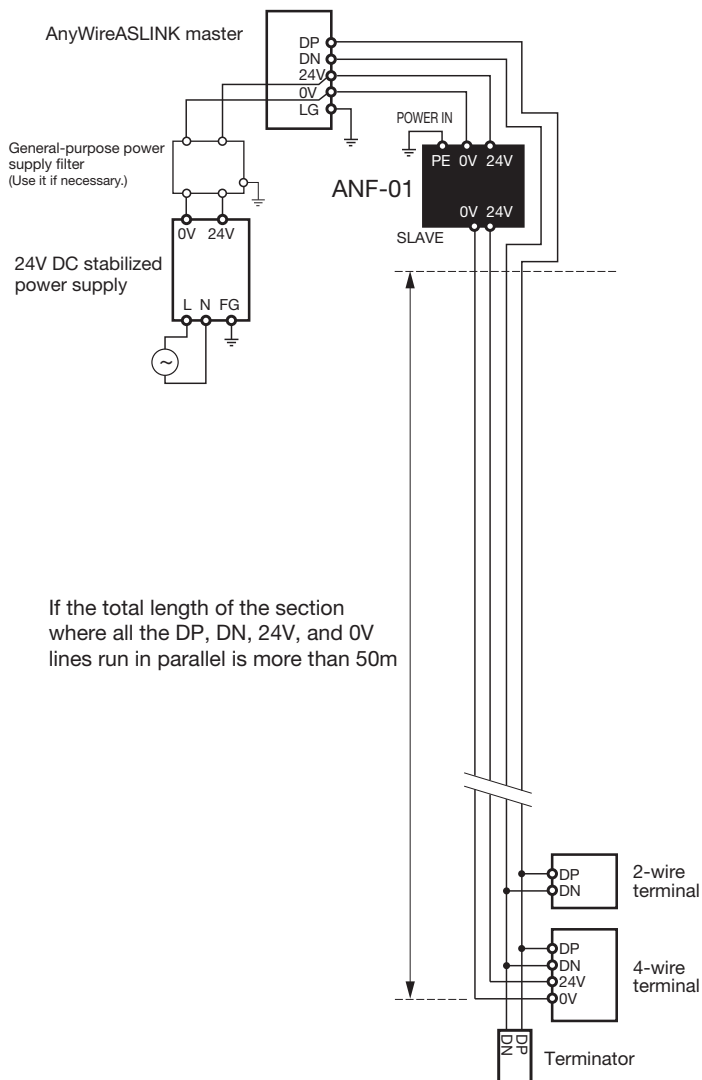

② Local power supply/branching

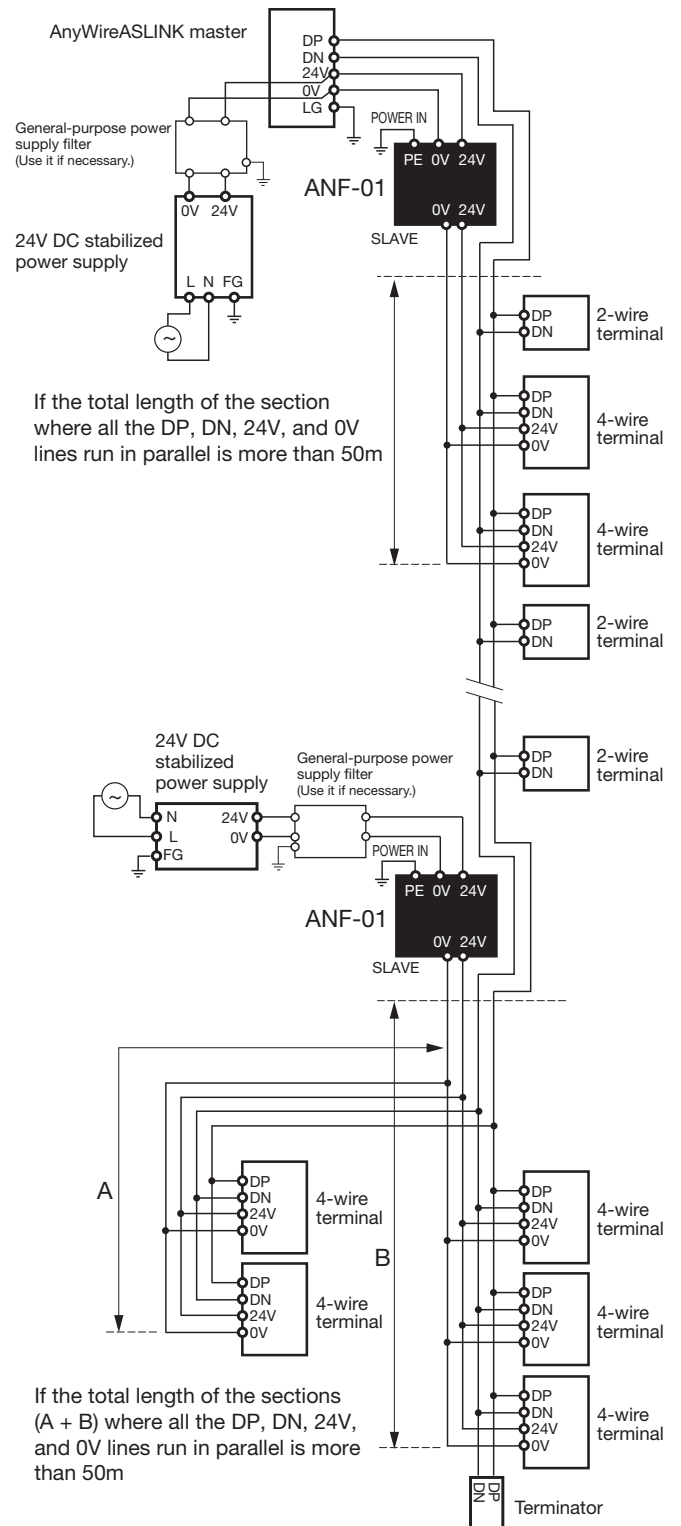

**Filter representation in the drawing**

For further information on ANF-01, refer to the product guide on ANF-01.

■ COSEL Co., Ltd. Type: EAC-06-472 Connection example

① Power supply to the entire system -----

\* When using this filter, please be careful of the positions of LOAD and LINE.

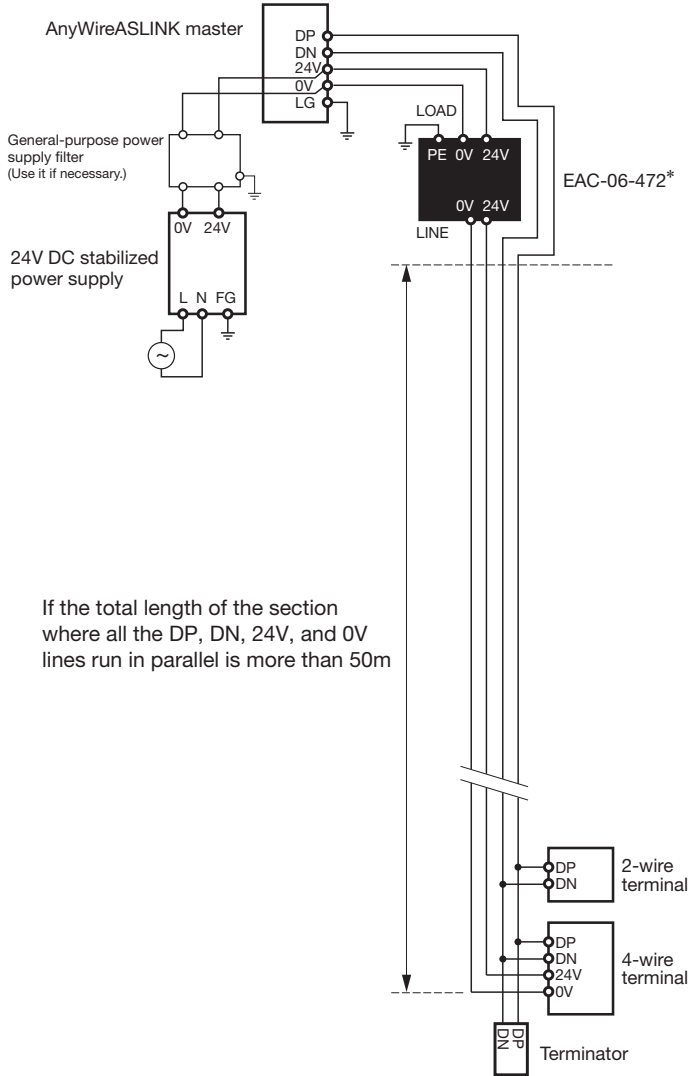

② Local power supply/branching -----

\* When using this filter, please be careful of the positions of LOAD and LINE.

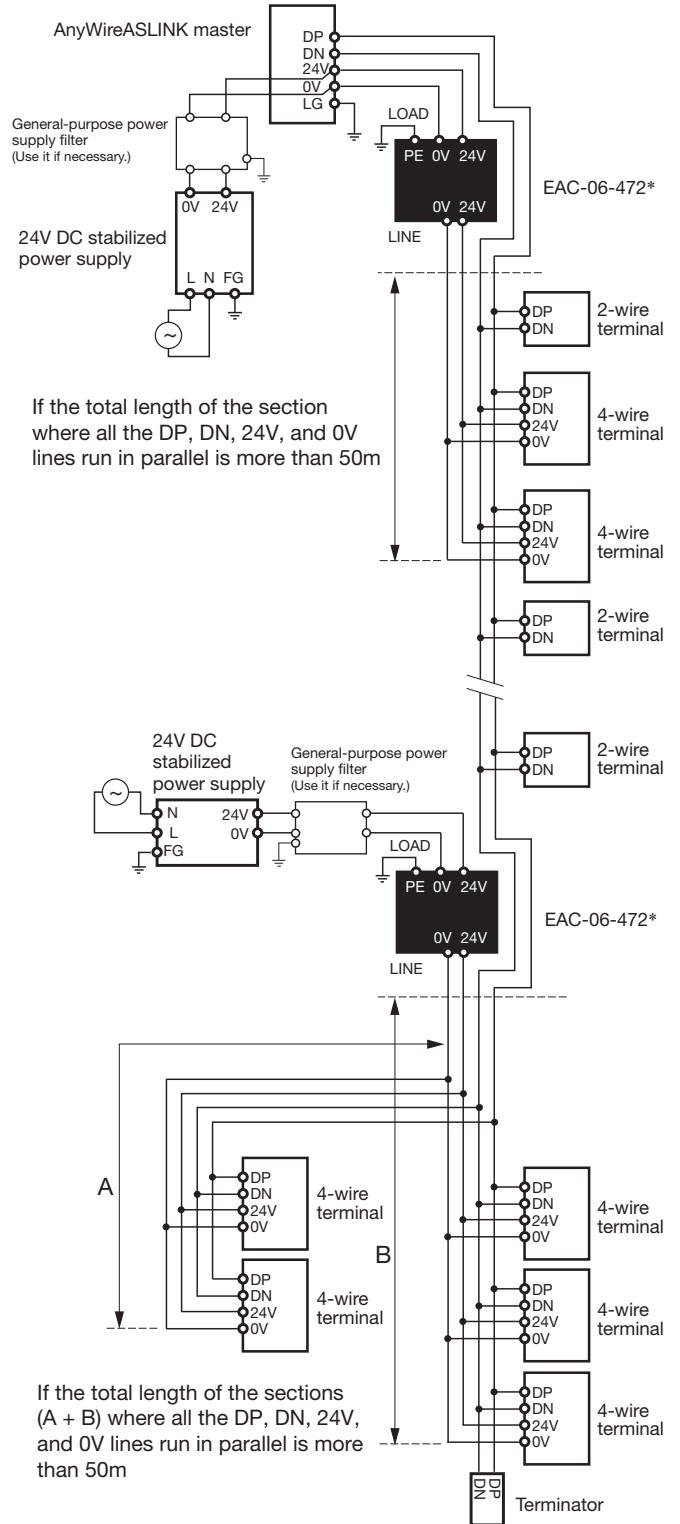

■ Filter representation in the drawing

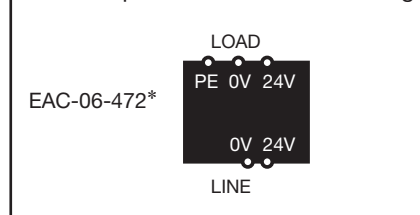

## [Connection Method]

Connect the transmission line included in the master unit to the transmission line of the AnyWireASLINK master unit. Make sure that connections of the positive and negative polarities are correct.

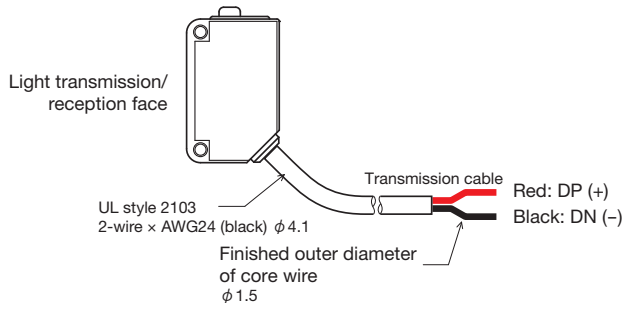

### Example of fitting the LP connector at the end of transmission line

Applicable LP connector: LP2-PWH-10P

Place the wires in the grooves so that the black wire (DN) is on the hinge side of the cover, fold A over B and engage the hook C to fasten it.

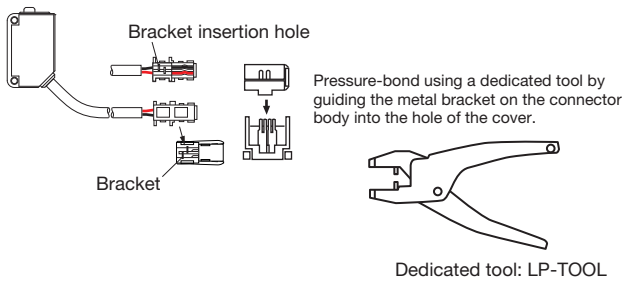
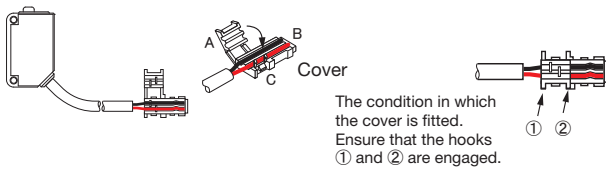

After pressure-bonding, ensure that the hooks ③ to ⑥ are securely engaged.

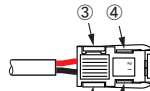

## [Installation Example]

The bracket should be purchased separately.  
M3 screw tightening torque: 0.25N·m or less

### CAUTION

To secure the sensor, allow some extra length on the cable so that the cable and the connectors would not be subjected to any stress. Do not tighten the screws too tight. Doing so may cause a failure or a shift of light beam.

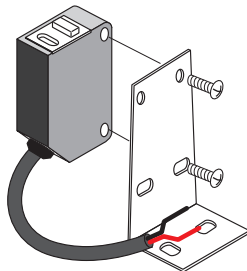

## [Installation Location]

- Locations where this product is not directly subject to vibration or shock
- Locations where this product is not exposed to dust and/or water continuously, even if it is waterproof
- Locations where this product is not directly exposed to conductors, such as metal chips or spatters
- Locations without condensation
- Locations where the atmosphere is free of corrosive gases, flammable gases, and sulfur
- Locations far from high-voltage or high-current cables
- Locations far from servos, inverters, and other cables and controllers that generate high-frequency noise
- Locations where this product is not directly exposed to the sunlight

## [Notes on the Use]

- This unit should be used by connecting it with the AnyWireASLINK transmission line. It will not work if it is connected directly to an I/O card for a PLC.
- Use it in an appropriate voltage range.
- The transmission line attached to ASLINKSENSOR should be counted in the determination of the total length.

## [Various Settings]

Address number setting    Teaching    Parameter setting

### Common procedure for address writer operation

Use the address writer with the sensor connected to the AnyWireASLINK master unit. An address writer ARW-04 (Ver. 04-1.01 or later) is required for the operation. For further information on the operation, refer to the product guide for the address writer.

1. Connect the terminal to the AnyWireASLINK master unit. Perform the setting using the address writer with the transmission signal (DP, DN) supplied.

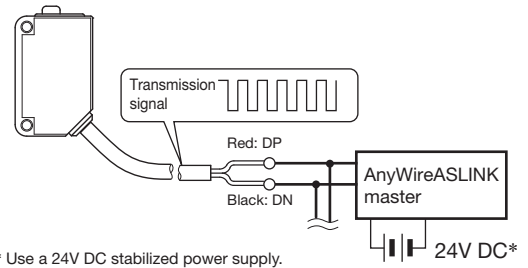

2. All terminals require settings. Perform the settings with the address writer pointed toward the setting port on the transmitter/receiver. (Hold the light emitting/receiving part as close as possible to the setting port.)

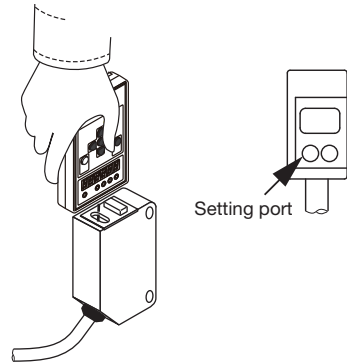

### Address number setting

For address numbers, specify the leading number of the transmission frames to be allocated to the terminal. The address numbers of this unit are set between 0 and 254.

### CAUTION

The factory setting of the terminal is "255," which means no setting. If the address number is set to 255, the terminal does not perform I/O operations. Before using the terminal, be sure to set an address number between 0 and 254.

## Teaching

Save the condition with and without a workpiece in the ASLINKSENSOR.

The setting procedure should be conducted with a workpiece to be actually used.  
To select the "0-100%" mode for the light receiving level indication setting (equipment parameter 08), be sure to conduct teaching.

[SET ON setting]

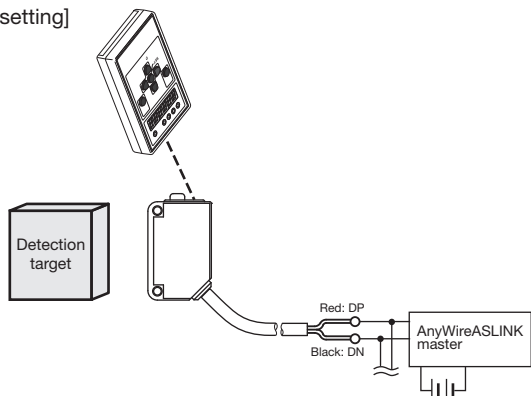

[SET OFF setting]

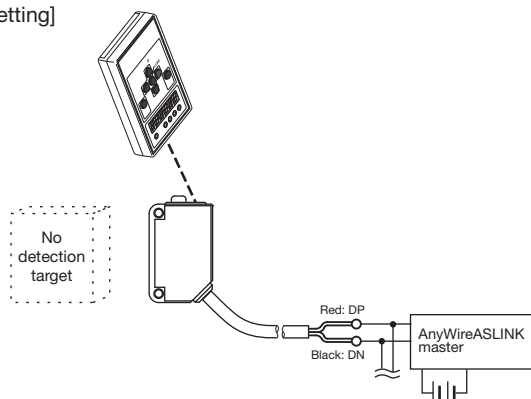

[Automatic setting for teaching]

If you conduct teaching when "AD value indication" is selected for the light receiving level indication setting (equipment parameter 08), "threshold," "hysteresis," "alarm Hi" and "alarm Lo" values will be automatically calculated and set at the following ratio, based on the difference in AD value between SET ON status (workpiece is present) and SET OFF status (no workpiece).

\* When the "0-100%" mode is selected for light receiving level indication setting (equipment parameter 08), the automatic setting function for teaching is disabled.

Threshold	50%
Hysteresis	5%
Alarm Hi	80%
Alarm Lo	20%

Example)

① SET ON   AD value for workpiece present status is "980."

② SET OFF  AD value for workpiece absent status is "0."

With the difference "980" in AD value between SET ON status and SET OFF status defined as the reference (100%), the following parameters will be automatically set.

Threshold (Equipment parameter 01): 490 (50%)

Hysteresis (Equipment parameter 02): 49 (5%)

Alarm Hi (Equipment parameter 03): 784 (80%)

Alarm Lo (Equipment parameter 04): 196 (20%)

## Parameter setting

### Threshold setting

This parameter determines the level of light to be received for detecting a workpiece.

\* The gap in the detection conditions stored in memory in teaching is assumed to be 100%.

- Address Writer (ARW-04): Parameter 01

AD value	0-100%	
0-1023	0-100%	Factory setting: 50 (AD value)

\* The setting range depends on the parameter 8 setting.

### Hysteresis setting

This parameter determines the light level required for the detection condition to change from ON to OFF.

- Address Writer (ARW-04): Parameter 02

AD value	0-100%	
0-1023	0-100%	Factory setting: 10 (AD value)

\* The setting range depends on the parameter 8 setting.

### Alarm Hi setting

This parameter determines the upper limit for issuing an alarm.

\* Set the alarm level so that the relationship  $Hi > Lo$  will be satisfied.

- Address Writer (ARW-04): Parameter 03

AD value	0-100%	
0-1023	0-100%	Factory setting: 0 (AD value)

\* The setting range depends on the parameter 8 setting.

### Alarm Lo setting

This parameter determines the lower limit for issuing an alarm.

\* Set the alarm level so that the relationship  $Hi > Lo$  will be satisfied.

- Address Writer (ARW-04): Parameter 04

AD value	0-100%	
0-1023	0-100%	Factory setting: 0 (AD value)

\* The setting range depends on the parameter 8 setting.

### Alarm monitoring time setting

This parameter determines the monitoring time of alarm determination.

- Address Writer (ARW-04): Parameter 05

Variable	Unit	
3-255	100ms	Factory setting: 50

### Light ON/Dark ON setting

This parameter determines Light ON or Dark ON.

- Address Writer (ARW-04): Parameter 06

Variable	Description	
0	Dark ON	Factory setting: 1
1	Light ON	

### Operation mode setting

This parameter disables/enables the preventive maintenance feature.

- Address Writer (ARW-04): Parameter 07

Variable	Description		
0	Simplified mode	Preventive maintenance feature disabled	Factory setting: 0
1	Normal mode	Preventive maintenance feature enabled	



## Light reception level indication setting

This parameter determines the light reception level indication. Based on this setting, parameters 01, 02, 03, 04 and the sensing level will be automatically set to the AD value or values in the range of 0 to 100%.

- Address Writer (ARW-04): Parameter 08

Variable	Description
0	AD value indication (0-1023 Digit)
1	0-100% indication

Factory setting: 0

\*Once a set value is changed by rewriting from the host, the values of parameters 01, 02, 03 and 04 will not be automatically converted.

## ON delay setting

This parameter determines the ON delay time.

- Address Writer (ARW-04): Parameter 10

Variable	Unit
0-999	100ms

Factory setting: 0

## OFF delay setting

This parameter determines the OFF delay time.

- Address Writer (ARW-04): Parameter 11

Variable	Unit
0-999	100ms

Factory setting: 0

## One Shot setting

This parameter determines the One Shot time.

- Address Writer (ARW-04): Parameter 12











Variable	Unit
0-999	100ms

Factory setting: 0

Parameter [9] and parameters from [13] onward are those in the system region. Do not modify these parameters with the address writer.

## Monitor Display

Normal condition: LINK flashing, ALM unlit and IN ON (lit) or OFF (unlit)

LED name	Display status	Description
LINK (Green)	Lit 	Transmission signal error
	Flashing 	Transmission signal supplied properly
	Unlit 	No transmission signal
ALM (Red)	Lit 	Sensing level drop
	Flashing 	Slave unit voltage drop
	Unlit 	Normal
LINK ALM	Alternate flashing LINK  ALM 	The master unit has detected that the unit ID (address) is either duplicated or unregistered
IN (Orange)	Lit 	ON
	Unlit 	OFF

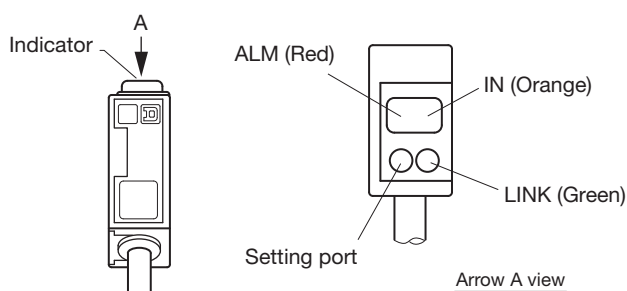

## Troubleshooting

If the following errors are indicated on the display window of ASLINKSENSOR, take the following actions.

LINK	IN	ALM	Cause	Remedy
○ Unlit	○ Unlit	○ Unlit	- The ASLINKSENSOR is not connected to the AnyWireASLINK system. - The AnyWireASLINK system is not turned on.	- Check if there is a disconnection between the ASLINKSENSOR and AnyWireASLINK system and, if there was a disconnection, restore the connection. - Check the power supply of AnyWireASLINK system and turn ON the power.
● Lit	○ Unlit	○ Unlit	- Connected directly to the 24-0V power supply.	- Reconnect the power to the AnyWireASLINK system.
⊙ Flashing (alternates with a 0.5 sec. interval)	○ Unlit	⊙ Flashing (alternates with a 0.5 sec. interval)	- The address of ASLINKSENSOR remains as "255" (factory setting). - The address of ASLINKSENSOR is duplicated.	- Assign an address other than 255. - Look for a unit that has the same error and assign an address different from the address of that unit.
—	—	⊙ Flashing (Lit for 0.2 sec., unlit for 1.0 sec.)	- The voltage of internal power supply for the ASLINKSENSOR is low.	- Reduce the number of units connected to the same AnyWireASLINK system. - Reduce the length of transmission line between ASLINKSENSOR and the master unit.
⊙ Flashing	—	● Lit	- The sensing level is low.	- Check the condition of ASLINKSENSOR, adjust the light beam and clean the transmission/reception face.

If the following error is indicated on the address writer, take the following action.

Display	Cause	Remedy
[E-0303]	The parameter setting is incorrect.	Refer to the parameter correspondence table and correct the setting.

Should any of the following apply, take the following actions.

Symptom	Remedy
Detection cannot be made	- Is the angle of transmission/reception face correct? → If the transmission/reception face is displaced, install the unit properly. - Is the wiring correct? → Re-check the connection of ASLINKSENSOR transmission line. - Is there a power supply with a capacity appropriate for the AnyWireASLINK master and slave units and turned ON? → Check the power supply. - Is the sensor used in the specified detection range? → Use it within its rating.
Setting cannot be made with the address writer	- Is the wiring correct? → Check the connection of ASLINKSENSOR transmission line once more. - Is the power supplied to the AnyWireASLINK system? → Check the power supply. - Are the parameters set correctly? → Refer to the parameter correspondence table and correct the setting.

## Equipment Parameters and Their Settings

Equipment parameter	Variable	Description	Factory setting
[01.] Threshold	0-1023 (0-100%)	The light reception level for the detection	50
[02.] Hysteresis	0-1023 (0-100%)	The change in the light reception level required for the detection status to change from ON to OFF	10
[03.] Alarm Hi	0-1023 (0-100%)	The upper limit of light reception level for issuing an alarm	0
[04.] Alarm Lo	0-1023 (0-100%)	The lower limit of light reception level for issuing an alarm	0
[05.] Alarm monitoring time	3-255	The time of monitoring the light reception level for issuing an alarm (1 = 100ms)	50
[06.] Light ON/ Dark ON	0	Dark ON	1
	1	Light ON	
[07.] Operation mode	0	Simplified mode (preventive maintenance feature disabled)	0
	1	Normal mode (preventive maintenance feature enabled)	
[08.] Light reception level indication	0	AD value indication (0-1023 Digit)	0
	1	0-100% indication	
[10.] ON Delay	0-999	The ON delay time (1 = 100ms)	0
[11.] OFF Delay	0-999	The OFF delay time (1 = 100ms)	0
[12.] One Shot	0-999	The One Shot time (1 = 100ms)	0

## [Specifications]

### ■ General specifications

Operating ambient temperature/humidity	0 – 55°C, 10 – 90%RH (No condensation)
Storing ambient temperature/humidity	-25 – 70°C, 10 – 90%RH (No condensation)
Operating ambient illuminance	Brightness on the reception face equivalent to 3000 lx of incandescent light
Vibration resistance	Based on JIS B 3502 and IEC 61131-2
Shock resistance	Based on JIS B 3502 and IEC 61131-2
Operating atmosphere	No corrosive gas
Operating altitude*1	0 – 2000m
Pollution level*2	2 or less

\*1 Do not use or store AnyWireASLINK devices in an environment where the pressure exceeds the atmospheric pressure at an altitude of 0 meters. Doing so may result in malfunction.

\*2 "Pollution level" is an index that indicates the degree of occurrence of conductive substances in the environment where the device is used.

Pollution level 2 means the occurrence of only pollution by non-conductive substances.

In such an environment, however, electrical conduction could occur due to accidental condensation.

### ■ Transmission specifications

Service power supply voltage	24V DC +15% to -10% (21.6 to 27.6V DC) with a ripple of 0.5Vp-p or less
Transmission method	DC power supply superimposed total frame/cyclic method
Synchronization method	Frame/bit synchronization method
Transmission procedure	AnyWireASLINK protocol
Connection mode	Bus type (Multi-drop method, T-branch method, Tree branch method)
Number of connection points	512 max. (IN: 256, OUT: 256)
Number of connection units	Up to 128 units
RAS function	Detection of transmission line disconnection, transmission line short-circuit, and transmission power supply drop Detection of duplicated/unregistered ID

### ■ Individual specifications

Number of occupied points	Input 1 point
Response time*3	1 – 2 cycles
Weight	33g
Detection method	Diffuse reflection
Detection distance	500mm (100 × 100mm white drawing paper)
Light source (illumination wavelength)	Red LED
Protective circuit	Short circuit protection of power supply, protection against reverse connection of power supply, prevention of mutual interference
Protection class*4	IP67 (Oil resistance under in-house standard)
Current consumption	10mA

\*3 Time required to send a transmission signal after detection of ON or OFF status.

"This time + 2-cycle transmission time" is defined as transmission delay time.

\*4 Oil resistance is verified with the oil or cutting fluid specified by in-house standard. This unit hardly suffers damage from oil, but it is not guaranteed to be free from damage. Do not use this unit in a place where it is always exposed to oil splash or stream.

\*Cutting oil specified by in-house standard

Water-insoluble (YUSHIRONCUT KM557, KZ313S), water-soluble (YUSHIROKEN EC50, AP-EX-E7, FGS700)

Immersion at 55°C ambient temperature

\*Lubricating oil specified by in-house standard (VELOCITY OIL No. 3)

Immersion at 55°C ambient temperature

## [Outside Dimensions]

Unit: mm

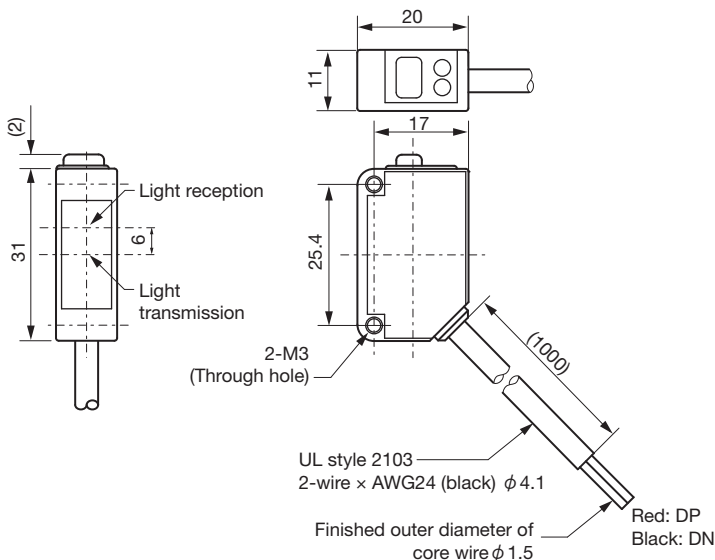

### 【中国版RoHS指令】

电子信息产品上所示标记是依据SJ/T11364-2006规定,按照电子信息产品污染控制标识要求制定。本产品的环保使用期限为10年,如果遵守产品说明书中的操作条件使用电子信息产品,不会发生因产品中的有害物质泄漏或突发异常而引发严重的环境污染、人身事故,或损坏财产等情况。

的产品中有害物质的名称及含量

部件名称	有害物质					
	铅 (Pb)	汞 (Hg)	镉 (Cd)	六价铬 [Cr (VI)]	多溴联苯 (PBB)	多溴二苯醚 (PBDE)
安装基板	×	○	○	○	○	○
框架	○	○	○	○	○	○

本表格依据SJ/T11364的规定编制。  
○：表示该有害物质在该部件所有均质材料中的含量均在GB/T26572规定的限量要求以下。  
×：表示该有害物质至少在该部件的某一均质材料中的含量超出GB/T26572规定的限量要求。



基于中国标准的参考规格：GB/T15969.2

### [Address]

**Anywire** Anywire Corporation

Headquarters :1 Babazusho, Nagaokakyo-shi, Kyoto 617-8550 JAPAN

Contact :Contact by mail info\_e@anywire.jp  
:Contact by website http://www.anywire.jp

Printed in Japan 2016,2017,2019 UMA-15452AD-EN