

ASLINKTERMINAL [ASLINK Relay Terminal]

BL296PB-08RS □

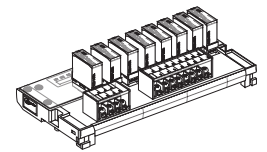

■ Note on use ⇒ A separate Address Writer is required to set addresses and other data.

* For more information, refer to [Various Settings] on page 10.

[Type]

BL296PB-08RS	With relay	
BL296PB-08RSN	Without relay	—

This product is a relay output terminal for AnyWire ASLINK system.

*1 Products with the last four digits of the Lot No. "CBNA" or later are UL compliant.

[Notes on Safety]

Precautions that must be observed in order to use this system safely are indicated as shown below.

You must observe these precautions.



A WARNING indicates a potentially hazardous situation which, if not handled correctly, could result in death or serious injury.



A CAUTION indicates a potentially hazardous situation which, if not handled correctly, may result in personal injury or property damage.



- System Safety
This system is intended for general industrial applications. It does not have functions for supporting applications requiring higher levels of safety such as safety-related devices or accident prevention systems. The product must not be used for these purposes.
- Before installation, replacement and/or cleaning of the product, be sure to turn OFF the power supply for the system.
- Prolonged continuous flow of a rated load current or higher or a transit current due to load short-circuit, etc., in the hybrid unit including the output unit and the output circuit may result in smoking or firing. An external safety device such as a fuse must be installed.
- If the equipment is used in a manner not specified by the manufacturer, the protection provided by the equipment may be impaired.



- System power supply
Use a stable, 24V DC power supply. Use of an unstable power supply may cause problems with the system.
- Separately route high-voltage and power cables
Although the AnyWireASLINK has a high noise margin, install the transmission line and I/O cables away from high-voltage and power cables.
- Connectors and terminals
 - Pay careful attention to the length and installation of cable wiring to ensure that connectors and cables are neither overloaded nor disconnected.
 - Make sure to prevent any metal objects from getting inside the connectors or the terminal blocks.
 - Short-circuits caused by metal objects or mis-wiring are likely to damage the device.
- Do not impose any external loads on the units. Doing so may cause a failure.
- Do not disconnect or reconnect between the transmission line and slave units when the transmission line is active. A malfunction may occur.
- Use the AnyWireASLINK within the range of the specifications and conditions shown below.
- The equipment is an Open-type device which is intended to be installed in a suitable external enclosure for fire, shock and mechanical protections.
- The 8-relay-outputs of one BL296PB-08RS can choose to connect to SELV power supply(ies) or AC Mains power supply(ies). But shall not connect to both SELV and AC Mains in one device. When any one of the relay outputs connects to AC Mains power supply, all the rest of relay outputs shall either connect to AC Mains power supply or leave disconnected. And, the AC Mains power supplies must come from same branch circuit.
- Equipment installation, wire insulations, routing and separations shall in compliance with NEC/CEC and any requirements from local authorities.
- Disconnect power to equipment and relay outputs before installing or servicing.

[Warranty]

■ Warranty period

The warranty on the delivered Product shall continue to be effective for one (1) year after the delivery thereof to a location as designated by the original owner.

■ Scope of warranty

Should a defect occur in any part of the Product during the foregoing warranty period when it is used normally in accordance with the specifications described in this Products Guide, the Company shall replace or repair the defect free of charge, except when it arises as a result of:

- [1] Misuse or abuse of the Product by the owner;
- [2] Fault caused by other than the delivered Product;
- [3] The unauthorized modification or repair of the Product by any person other than the Company's personnel;
- [4] Any unusual force of nature, disaster or other cause beyond the Company's control.

The term "warranty," as used herein, refers to the warranty applicable to the delivered product alone. The Company shall not be liable for consequential or incidental damages resulting from any malfunction.

■ Repair at cost

After the expiration of the warranty period, the owner shall be responsible for all costs and expenses incurred for the troubleshooting and repair of the Product.

Even during the warranty term, the Company shall repair any defects arising from causes other than within the scope of the warranty as specified above, at the owner's cost.

- Changes in the product specifications and the descriptions in the manual
The descriptions in this manual may be subject to change without notice.

[About Pictogram*2]

	Ver. 1.0*3		Compatible with Ver. 1.1*4
---	------------	---	----------------------------

*2 The pictogram may not be marked (or stuck) depending on the product.

*3 AnyWireASLINK device not compatible with Ver. 1.1 (word transmission and single unit simplified replacement functions)
Some products, not marked with the Ver. 1.1 pictogram, are compatible with the functions included in Ver. 1.1. Refer to the lot No. and the product guide for ultimate confirmation.

*4 For details of Ver. 1.1, refer to the subsequent pages.

[About AnyWireASLINK Ver. 1.1]

New functions have been added to AnyWireASLINK products in May 2019 onward. Also, for the purpose of differentiation of compatible functions, indication of product lot number (lot No.) has been changed.

Compatible functions vary depending on lot No. Please understand the following description thoroughly to use each product.

Functions added to Ver. 1.1 are as follows:

Functions available with Ver. 1.1	Word transmission ^{*1*2}
	Single unit simplified replacement ^{*1}

*1 To use these functions, the master unit compatible with each function is required.

For details, refer to this manual together with the manual for the master unit.

*2 You can use this function with the word-transmission AnyWireASLINK unit connected.

To handle word data, word address settings are required for slave units.

It depends on slave units whether word address setting is enabled or not.

[About Lot No.]

As a result of the addition of functions, indication of lot No. has been changed from 3 digits (conventional format: year and month only) to 6 digits or 7 digits.

Example:

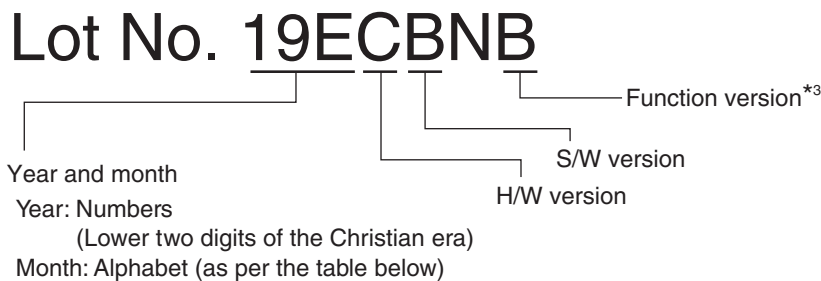

Alphabet	A	B	C	D	E	F	G	H	I	J	K	L
Month	1	2	3	4	5	6	7	8	9	10	11	12

“19E” means May 2019.

*3 Some products have no indication of function version.

[About Word Transmission]

The master unit compatible with the word transmission function provides areas for transmission and receiving of word data (numerical information) such as analog data and sensing level data.

Using this function enables reduction of occupancy of bit information area by word data.

To enable word transmission, it is necessary that the system should be configured only with slave units compatible with the word transmission function.

A slave unit incompatible with the word transmission function cannot be connected to the AnyWireASLINK system to conduct word transmission.

For slave units that handle word data, word address settings are required.

[About Single Unit Simplified Replacement]

During replacement of a slave unit, this function enables automatic settings of address and parameters of the existing slave unit into a new slave unit. (After replacement of the slave unit, address and parameter setting procedure using the address writer is not required.)

■ Step 1 Turn OFF the 24V DC power supply for the master unit.

■ Step 2 Disconnect a slave unit to be replaced.

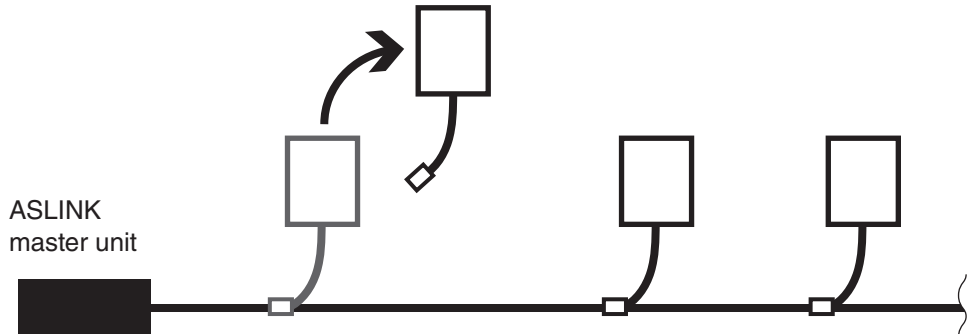

■ Step 3 Connect a new slave unit.

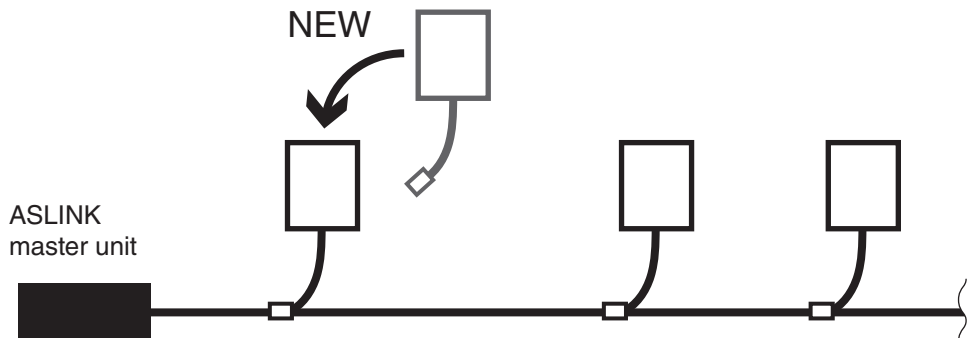

■ Step 4 Turn ON the 24V DC power supply to the master unit.



- CAUTION**
- It is necessary that both the master unit and slave unit should be compatible with the single unit simplified replacement function.
 - Before disconnection and connection of the slave unit, be sure to turn OFF the power supply.
 - For compatibility of a slave unit with the single unit simplified replacement function, see the lot No. and the manual for the slave unit.
 - When a slave unit of a new function version is replaced with that of an old function version, the single unit simplified replacement function cannot be used.
 - Operation is enabled in the case where the model of the slave unit before replacement is the same as that after replacement.
 - If the model of the slave unit before replacement is different from that after replacement, a model mismatching error occurs, disabling address and parameter settings.
 - Operation is enabled in the case where the address of the slave unit for replacement is the factory-set address (bit address 511).
 - Several slave units cannot be simultaneously replaced. For replacement of several slave units, conduct the replacement procedure for each unit one by one.
 - For a slave unit incompatible with the single unit simplified replacement function, set an address and parameters by using the address writer as in the conventional manner.
 - For details of the single unit simplified replacement function (limitations, conditions, etc.), refer to the manual for the master unit.

■ Identification of function version

Function version information is given on the lot label.

* The design and contents of the lot label may vary depending on the product model and lot No.

Anywire Corporation	
MODEL	_____
DATE	2019-05
Lot	19ECB(8)
_____	_____
_____	_____
MADE IN JAPAN	

Function version:

When an equipment parameter is changed due to functional upgrading, etc., the function version will be updated (for example: A→B→C).
When a slave unit of a new function version is replaced with that of an old function version, the single unit simplified replacement function cannot be used.

[Functions]

■ Function list

Model	Specifications	Connection targets	Functions					Address	
			Bit transmission	Word transmission ^{*1*2}	Single unit simplified replacement ^{*1*3}	Remote address change ^{*1*3}	Detection of sensor cable disconnection	Bit address setting	Word address setting
ASLINKTERMINAL 4-wire (isolated) relay terminal	a-contact relay output: 8 points	General-purpose output devices	○	○	○	○	×	○	×

*1 It depends on lot No. whether this function is available or not.

*2 This terminal can be used in connection to the AnyWireASLINK unit for word transmission. Note that this terminal cannot handle word data by setting a word address.

*3 To use these functions, a master unit that supports each function is required. For details, refer to the manual for the master unit together with this manual.

■ Detecting functions (Status details)

Functions				
Slave unit voltage drop	Sensing level drop	I/O disconnection	I/O short-circuit	I/O power supply drop
○	×	×	×	○

[Function Compatibility by Lot No.]

This unit has undergone addition of functions and change of specifications according to version upgrading. Available functions and specifications of the unit vary depending on lot No.

Function	Lot No.
Word transmission ^{*4}	Available with S/W version "B" or later version (If lot No. is indicated in 3 digits (year and month only), these functions are not available.)
Single unit simplified replacement	
Remote address change	

*4 This terminal can be used in connection to the AnyWireASLINK unit for word transmission. Note that this terminal cannot handle word data by setting a word address.

■ How to check

Lot No. is indicated on the lot label.

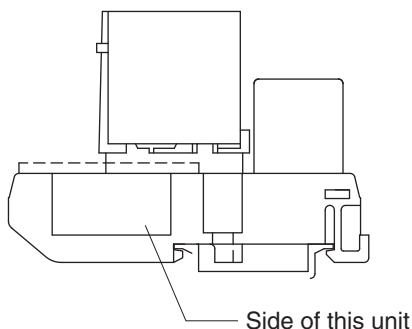

Example:

Lot No. 19ECBNB

H/W version ————
S/W version ————
Function version ————

[How to Connect AnyWireASLINK]

The AnyWireASLINK can employ a two-wire or four-wire terminal selectively depending on the load current. If the load current is small, using a two-wire (non-isolated) terminal allows for achieving simplified wiring without local power supply. In the case of prioritizing the sites of concentrated loads and/or the number of connections, hybridization with a four-wire (isolated) terminal, which supports local power supply, is also possible. Make sure to use a four-wire (isolated) terminal in the case of input and load driving using an external power supply.

[System Configuration Example]

Relationship between the size and length of the transmission line and the supply current (Table 1)

Size of the transmission line (DP, DN)	Supply current on the transmission line (DP, DN)		
	Total length: 50m or less	Total length: Over 50m, no longer than 100m	Total length: Over 100m, no longer than 200m
1.25mm ²	MAX 2A	MAX 1A	MAX 0.5A
0.75mm ²	MAX 1.2A	MAX 0.6A	MAX 0.3A
0.5mm ²	MAX 0.8A	MAX 0.4A	MAX 0.2A

CAUTION

- Refer to Table 1 so that the size and length of the transmission line and the allowable supply current lie within an appropriate range.
- Connect the same symbols (DP, DN) correctly between the AnyWireASLINK master unit and each device.
- The branching length or branch number has no limitation.
- Include the length of the cable provided with the terminal in the "total line length."
- Connect the terminator (with polarity) to the DP, DN terminal farthest from the AnyWireASLINK master unit.

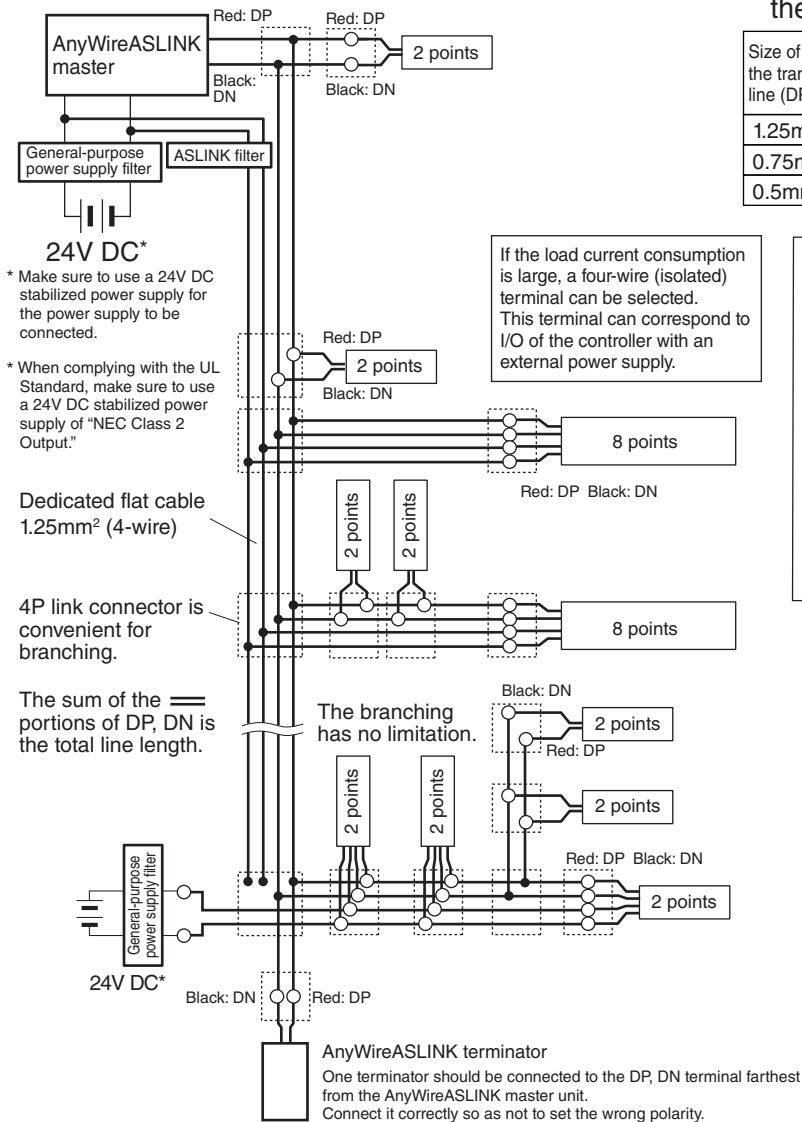

[Installation Location]

- Install in the following indoor locations.
- Locations where this product is not directly subject to vibration or shock
 - Locations where this product is not directly exposed to dust
 - Locations where this product is not directly exposed to conductors, such as metal chips or spatters
 - Locations without condensation
 - Locations where the atmosphere is free of corrosive gases, flammable gases, and sulfur
 - Locations far from high-voltage or high-current cables
 - Locations far from servos, inverters, and other cables and controllers that generate high-frequency noise

[Mounting method]

The device can be mounted on DIN rails.
Note that there are restrictions on the mounting orientation.

■ Mounting orientation

Vertical mounting (landscape orientation)

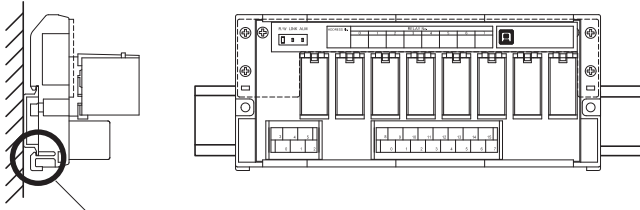

Movable hook (bottom)

Horizontal mounting

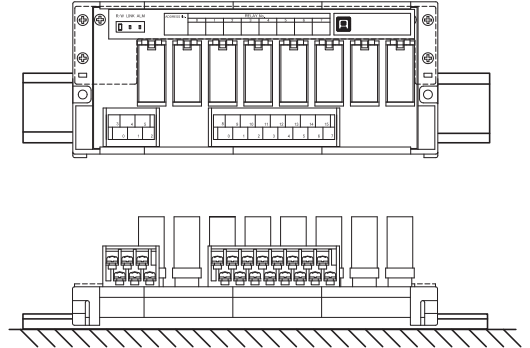

Vertical mounting (portrait orientation)

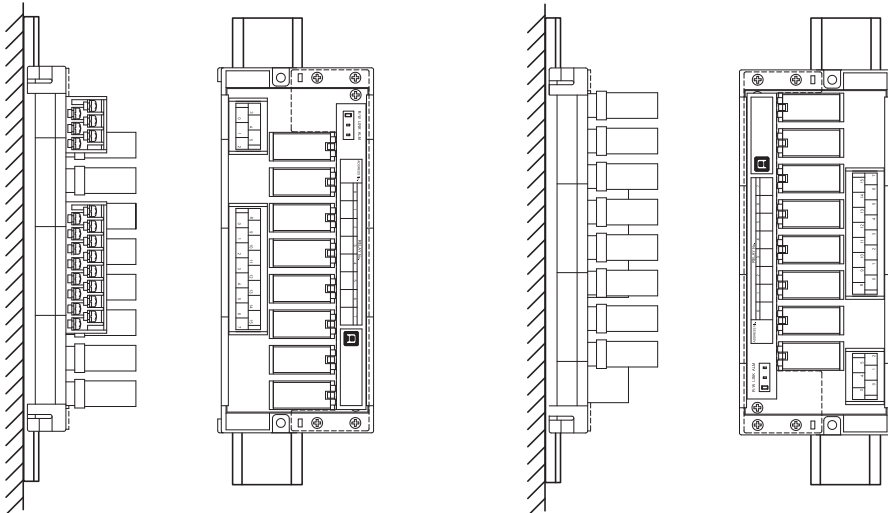

In all mounting orientations, use DIN rail stoppers to prevent misalignment.

*Do not mount with the movable hook on top or with the terminal upside down.

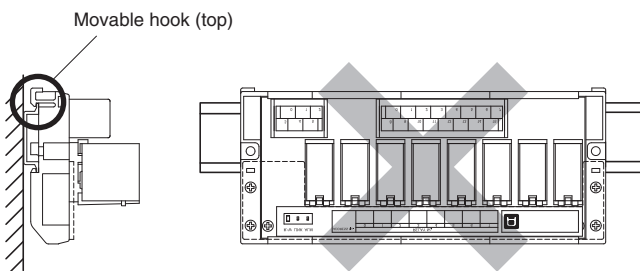

Movable hook (top)

[Notes on Combined Use with 4-Wire (Isolated) Terminal]

If the total length of the sections where all the DP, DN, 24V, and 0V lines run in parallel in the power supply system is more than 50m, connect an ASLINK filter (Type ANF-01) or a filter manufactured by COSEL Co., Ltd. (Type EAC-06-472) in series to the 24V and 0V lines at a position where these four lines start running in parallel.

This will improve noise resistance, suppress the adverse effects of crosstalk caused by transmitted signals, and stabilize signals.

The above filters must be inserted regardless of whether power is supplied to all terminals collectively from the power supply for the master or power is supplied to each terminal individually from their local power supply.

Insert the "ASLINK filter [Type ANF-01]" regardless of installation method and distance when complying with CE Standard.

Filter allowable current

Product	Type	Allowable power current
ASLINK filter	ANF-01	MAX 5A/24V DC
Filter of COSEL Co., Ltd.	EAC-06-472	MAX 6A/24V DC

AnyWire Type: ANF-01 Connection example

① Power supply to the entire system

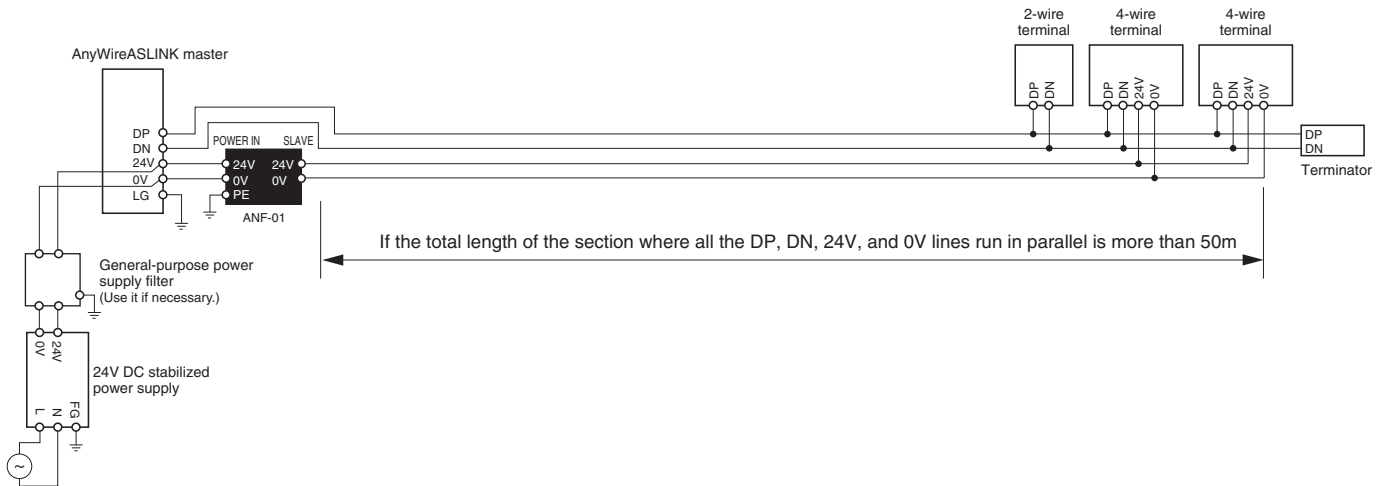

② Local power supply/branching

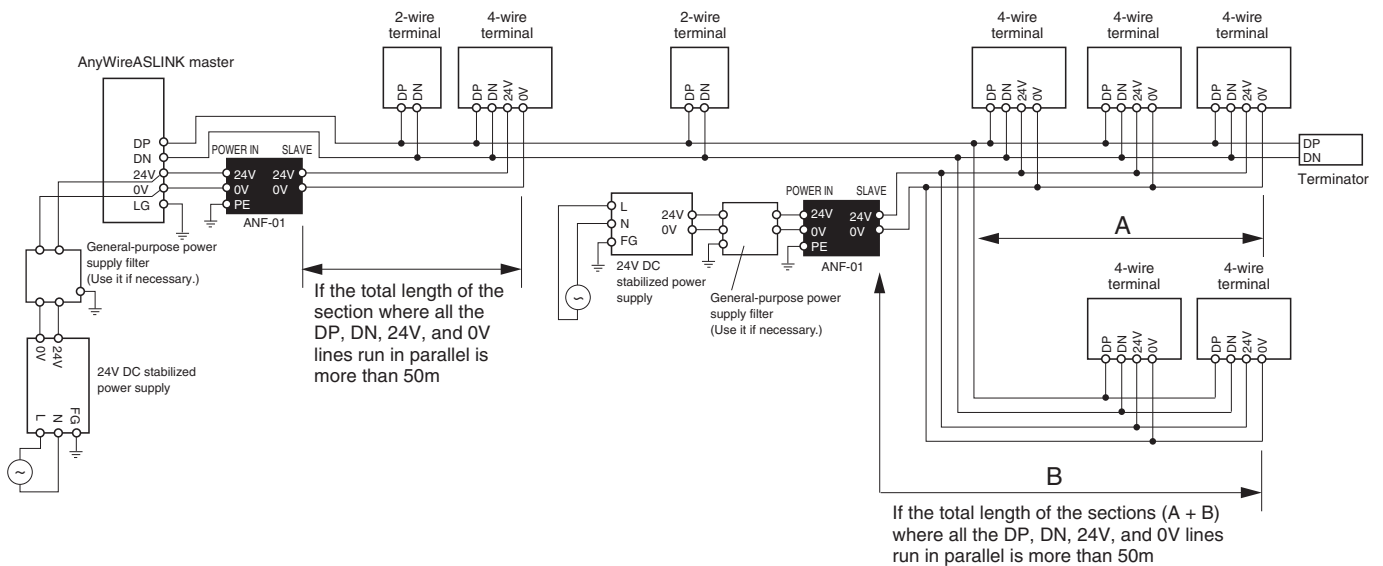

① Power supply to the entire system

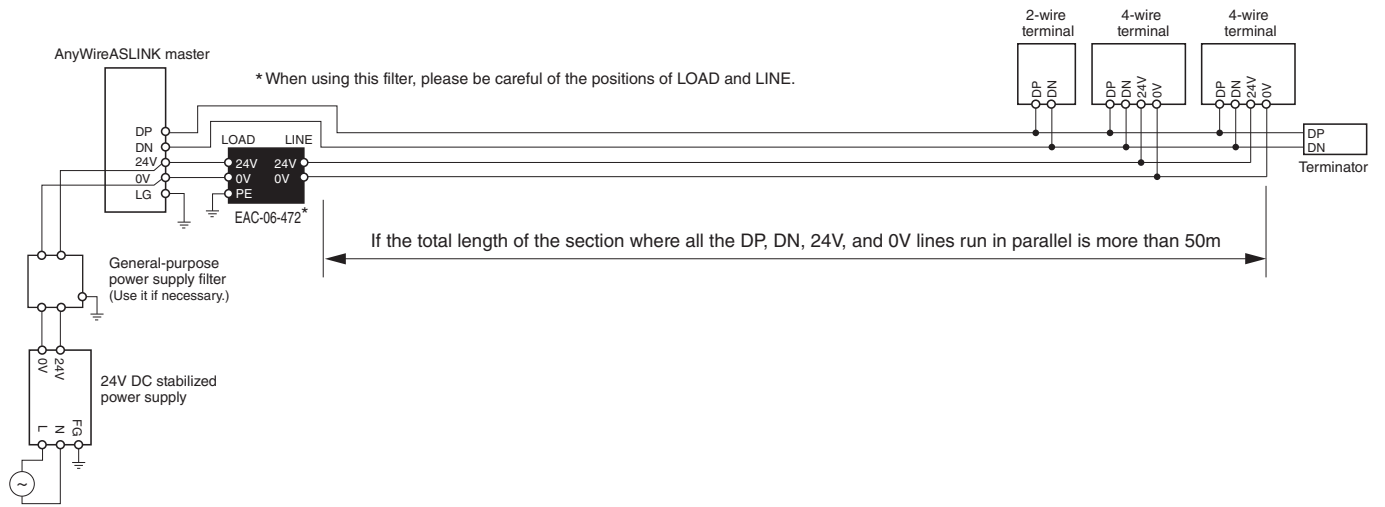

② Local power supply/branching

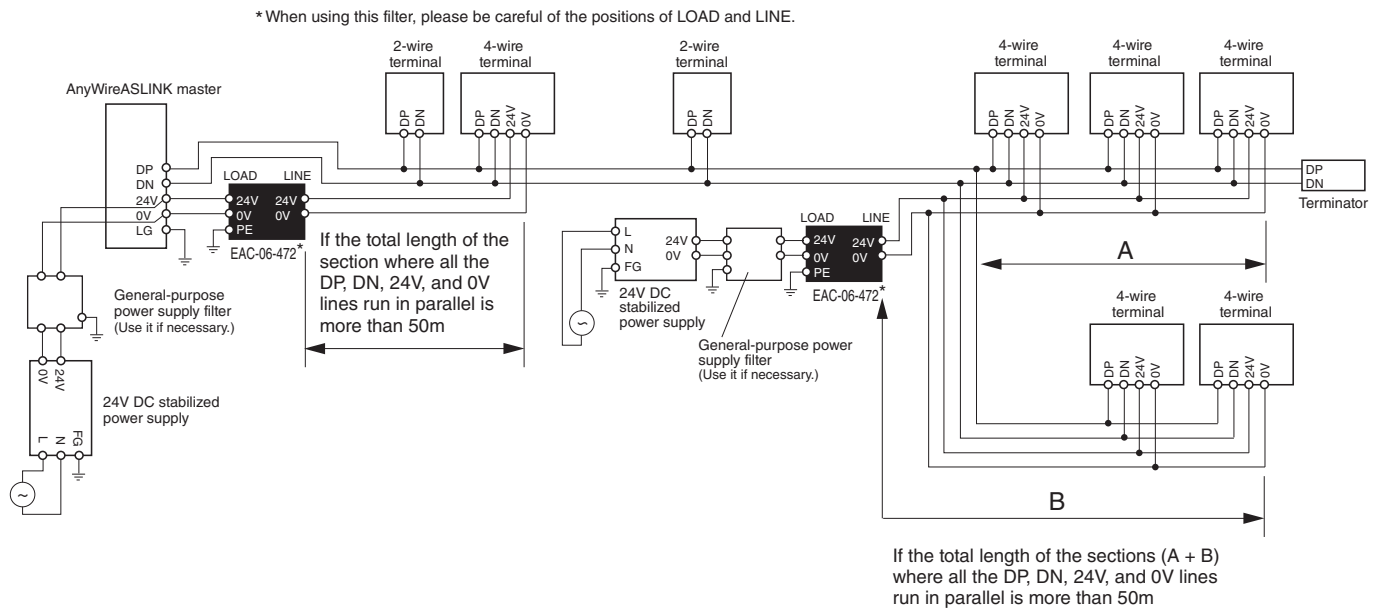

[Name of Each Part]

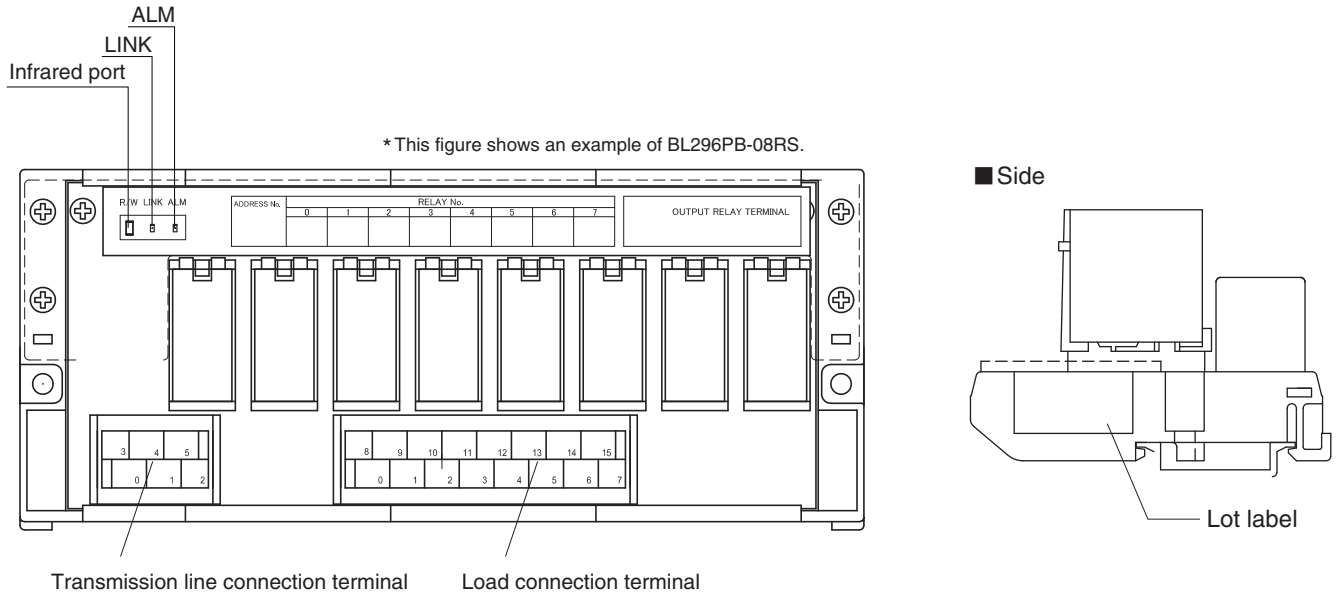

[Terminal Layout]

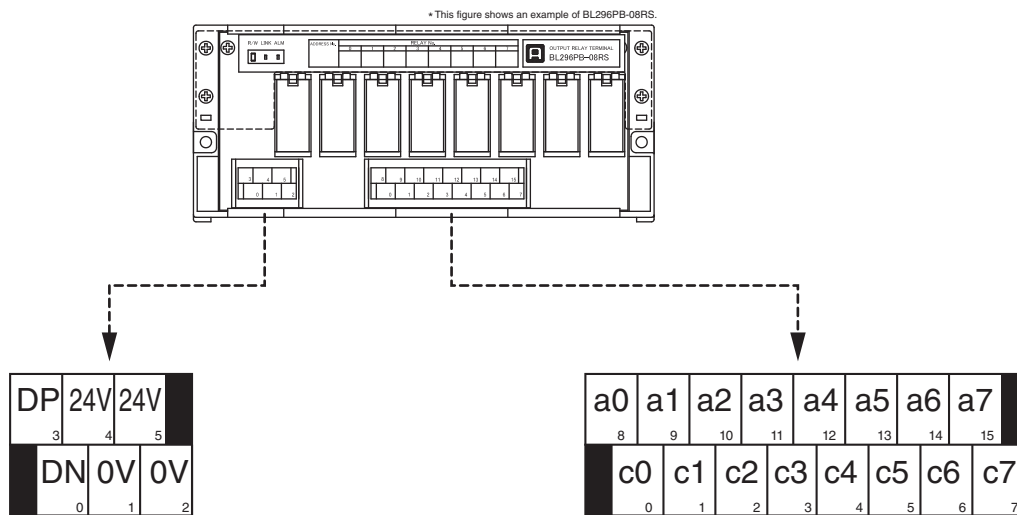

【Transmission line connection terminal】

DP: Transmission line (+)
 DN: Transmission line (-)
 24V: Relay drive power supply (+)
 0V: Relay drive power supply (-)

Connect a transmission line to the DP and DN terminals.
 Ensure connection with correct polarity.
 The 24V and 0V terminals are used to connect power supplies for relay drive output circuit and coil.

Copper wire only, 18 AWG, 90°C building wire to be used for relay outputs.



Do not touch terminal blocks and cables directly with your hands when power is supplied as this may cause an electric shock.

【Load connection terminal】

There is an independent a-contact circuit between terminals a□ and c□.
 Eight circuits are provided in total.

● Terminal specifications (Common to transmission line and load)

Connecting method	Stranded wire or crimp terminal
Screw	M3
Tightening torque (N·m)	0.5 to 0.8
Applicable wire (mm ²) [AWG]	0.3 to 1.25 [22 to 16]

● Crimp terminal
 Applicable crimp terminal is as shown on the right.

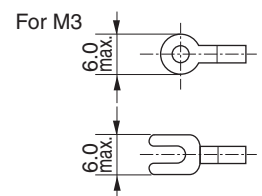

[Various Settings]

Address setting

■ Common procedure for address writer operation

Be sure to connect to the AnyWireASLINK master unit to use.
ARW-04 (address writer) of Rev. (Ver.) 1.01 or later version, or ARW-03 of Rev. (Ver.) 2.10 or later version is required for address setting.
For the details of the operating method, refer to the product guide of the address writer.

Connect this unit to the AnyWireASLINK master unit.
Set an address with the address writer with the transmission signal (DP/DN) and power supply (24V/0V) being connected.

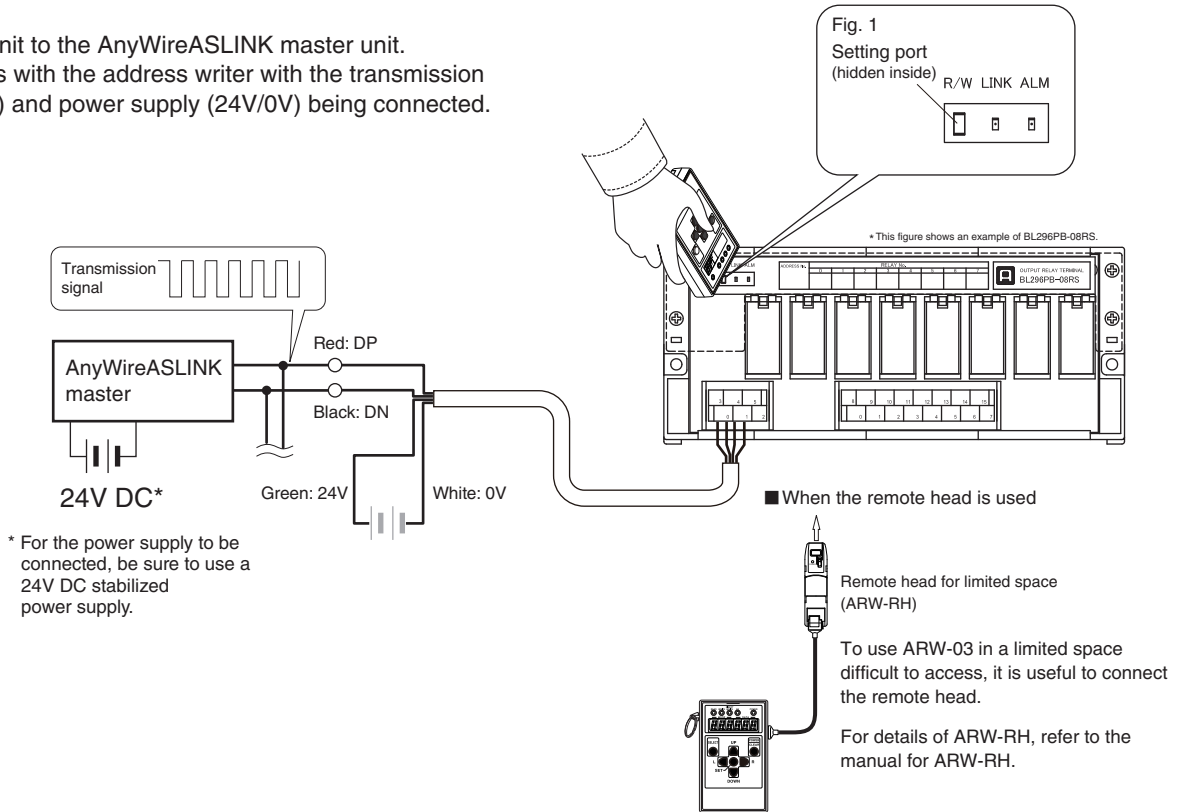

Address setting

An address number is set as a beginning number from which part of the transmission frame is occupied to the terminal.
Set the address number within the range of bit address "0 to 254."

- Set the address number so that the area occupied by the terminal does not exceed the transmission points of the master unit.
- Make sure that the address number setting is not duplicated.
- Also, use the address writer to read an address number that has been written in the terminal.



The factory-set address is "bit address 255" or "bit address 511," which indicates that an address has not been set.

The factory-set address varies depending on lot No., as follows:

For S/W version "B" or later version: Bit address 511

For S/W version "A" or 3-digit lot No.: Bit address 255

Input and output operations are disabled with the factory-set address.

Example:

Lot No. 19ECBNB

└ S/W version

[Data Configuration]

BL296PB-08RS□

Address offset	n+7	n+6	n+5	n+4	n+3	n+2	n+1	n
Bit output	OUT7	OUT6	OUT5	OUT4	OUT3	OUT2	OUT1	OUT0

*n = Bit address number assigned to this unit

■ Status details

The contents of an alarm detected with this unit can be checked with the “status detail area^{*1}” on the master unit.

A bit corresponding to the status detail area turns ON depending on the contents of the alarm.

Status detail area of the master unit











Status details	b15	b14	b13	b12	b11	b10	b9	b8	b7	b6	b5	b4	b3	b2	b1	b0
----------------	-----	-----	-----	-----	-----	-----	----	----	----	----	----	----	----	----	----	----

b0: Slave unit voltage drop (DP-DN-side voltage drop)

b5: I/O power supply drop (24V-0V-side voltage drop)

*1 This can be used on the master unit having the status detail area. For details, refer to the manual for the master unit.

[Monitor Display]

LED name	Display status	Description
LINK (Green)	Lit 	Transmission signal error Model mismatching error ^{*2}
	Flashing 	Transmission signal received
	Unlit 	No transmission signal (disconnection and reverse connection of DP and DN lines included)
ALM (Red)	Lit 	I/O power supply drop
	Flashing 	Slave unit voltage drop Model mismatching error ^{*2}
	Unlit 	No ALM available
LINK ALM	Alternate flashing LINK  ALM 	ID duplicated ^{*3} or ID unregistered ^{*4}
LINK ALM	LINK  ALM 	Model mismatching error ^{*2}

*2 This indication appears when the use of the single unit simplified replacement function fails. (This operation occurs on the S/W version “B” or later version.)

*3 If ID duplication is detected when the master unit executes automatic address recognition, this indication appears.

*4 For S/W version “B” or later version: This indication appears when transmission signal and power supply are normally connected, and the unit is set to the factory-set address. For S/W version “A” or 3-digit lot No.: This condition is detected when the master unit executes automatic address recognition.

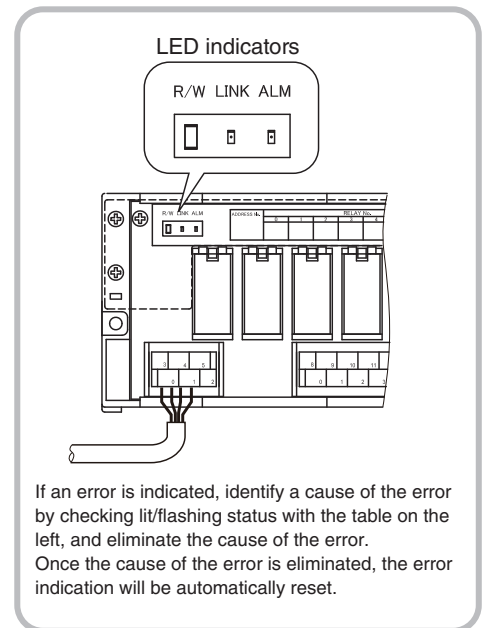

If an error is indicated, identify a cause of the error by checking lit/flashing status with the table on the left, and eliminate the cause of the error. Once the cause of the error is eliminated, the error indication will be automatically reset.

[Troubleshooting]

<LINK does not flash>

Things to be checked	Remedy
Check the connection of this unit.	Disconnect this unit once, and then reconnect it.
Check conditions of the master unit and slave unit.	<ol style="list-style-type: none"> 1) If LINK on the master unit is flashing and LINK on the slave unit is lit, it is possible that the master unit has a fault or power supply (24V-0V) is directly connected to the DP-DN pins of the slave unit. * If LINK is lit while ALM is flashing, it means a failure in single unit simplified replacement. 2) If LINK on the master unit is flashing and LINK on the slave unit is unlit, it is possible that the power (24V DC) is not supplied to the master unit, there is a disconnection on the transmission line (DP, DN), or the slave unit has been damaged. 3) If LINK on the master unit is not flashing, check the power supply to the master unit. Also, since there is a possibility that some system error has occurred, refer to the user's manual of the master unit. 4) A slave unit incompatible with Ver.1.1 cannot be used in connection to the AnyWireASLINK system for word transmission. Check the setting of the master unit, and lot No. of the slave unit.

<ALM is lit>

Things to be checked	Remedy
Check the connection of I/O terminals on the slave unit.	<p>Adjust the voltage of external power supply connected to the I/O side of the slave unit so that it falls within the rating (21.6 to 27.6V).</p> <p>In addition, ensure that there is no contact between and erroneous wiring of transmission lines.</p>

<ALM is flashing>

Things to be checked	Remedy
Check the voltage (24V DC) of external power supply to the master unit.	<p>Adjust the voltage of external power supply to the master unit so that it will be in the range from 21.6 to 27.6V. (Recommended voltage is 26.4V.) Check the total length.</p> <p>Review the total length and wire diameter of transmission line so that the load will not exceed the current limit supplied by the transmission line and adjust the connected load. (In the case of the wire size of 1.25mm² and total length of 50m or less, the current supplied by the transmission line is 2A.)</p> <p>* If ALM is flashing while LINK is lit, it means a failure in single unit simplified replacement.</p>

<LINK and ALM flashes alternately>

Things to be checked	Remedy
Check the address of the slave unit.	<p>The address of the slave unit is either unregistered or duplicated.</p> <p>Take the following actions. * The slave unit cannot be used with the factory-set address.</p> <ol style="list-style-type: none"> 1) Set an address correctly. 2) Check if there is a slave unit on which the indicator lamps are flashing in the same manner and reset the addresses so that they are not duplicated.

<LINK is lit and ALM is flashing: Model mismatching error (Failure in single unit simplified replacement)>

Things to be checked	Remedy
Check the connection of the slave unit.	<p>Defective connections and the like may have caused single unit simplified replacement to fail. Remove the slave unit after replacement, and make connections again.</p> <p>* When two or more replacement slave units are simultaneously connected, the single unit simplified replacement function does not work.</p>
Check the address of the slave unit.	<p>Check if the address of the replacement slave unit is the same as the address before shipment (a bit address of 511).</p> <p>* If the address of the replacement slave unit is not the same as the address before shipment, the single unit simplified replacement function does not work.</p>
Check the model of the slave unit.	<p>Check if the replacement slave unit is of the same type as that of the slave unit before the replacement.</p>
Check the lot No. of the slave unit.	<p>Check if the function version for the replacement slave unit is older than that of the slave unit before the replacement.</p> <p>* If the function version of the replacement slave unit is older, the single unit simplified replacement function does not work.</p>

[Configuration and Electrical Characteristics of Output Circuit]

BL296PB-08RS

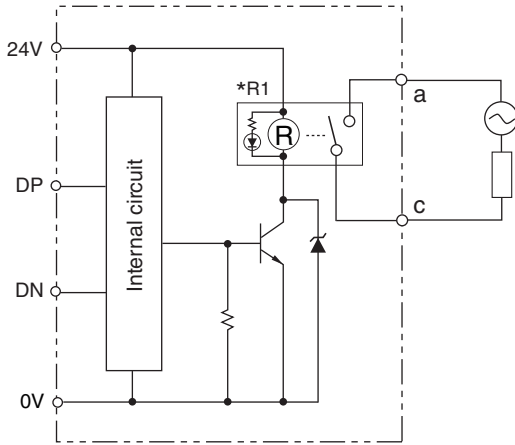

*R1: Not provided for BL296PB-08RSN.
It is useful to select the model with LED indication (G2R-1-SN, etc.) to check operation of the incorporated relay.

CAUTION

To open/close the circuit together with a load that may generate a surge, be sure to provide a surge killer for the load. Failure to observe this instruction may cause interference.

<Output circuit>

One output circuit: 3A (max.)
Terminal block: 10A (max.)

<Incorporated relay>

Model: OMRON G2R-1-SN
Rated load: 250V AC 10A (Resistance load)
30V DC 10A (Resistance load)
250V AC 7.5A (Inductive load)
30V DC 5A (Inductive load)
Rated allowable current: 8A
Maximum contact voltage: 380V AC, 125V DC
Maximum contact current: 8A
Maximum opening/closing frequency:
Mechanical: 18000 times/h
Rated load: 1800 times/h
Durability: Mechanical: 10 million times or more
Electrical: 100 thousand times or more/rated load
(at the above maximum opening/closing frequency)

The 8-relay-outputs of one BL296PB-08RS can choose to connect to SELV power supply(ies) or AC Mains power supply (ies). But shall not connect to both SELV and AC Mains in one device. When any one of the relay outputs connects to AC Mains power supply, all the rest of relay outputs shall either connect to AC Mains power supply or leave disconnected.

Total 8 relay outputs. Maximum load for each individual relay output: SELV 0-30Vdc 3A resistive, OR, AC Mains up to 250Vac 3A resistive, 3A General purpose or 1/4 horsepower, Overvoltage Category II, Pollution degree 2. Maximum total load of total 8 relay outputs: 10A.

[Specifications]

■ General specifications

Operating ambient temperature/humidity	0 to +55°C, 10 to 90%RH No condensation
Storing ambient temperature/humidity	-25 to +75°C, 10 to 90%RH No condensation
Vibration resistance	Based on JIS B 3502 and IEC 61131-2
Shock resistance	Based on JIS B 3502 and IEC 61131-2
Atmosphere	No corrosive gas
Operating altitude*1	0 to 2000m
Pollution level*2	2 or less
Overvoltage Category	II

- *1 Do not use or store AnyWireASLINK devices in an environment where the pressure exceeds the atmospheric pressure at an altitude of 0 meters. Doing so may result in malfunction.
- *2 "Pollution level" is an index that indicates the degree of occurrence of conductive substances in the environment where the device is used.
Pollution level 2 means the occurrence of only pollution by non-conductive substances.
In such an environment, however, electrical conduction could occur due to accidental condensation.
The equipment is intended to be powered by NEC/CEC Class 2, LPS or Limited Energy power source.

■ Transmission specifications

Service power supply voltage	24V DC +15% to -10% (21.6 to 27.6V DC) with a ripple of 0.5Vp-p or less
Transmission method	DC power supply superimposed total frame/cyclic method
Synchronization method	Frame/bit synchronization method
Transmission procedure	AnyWireASLINK protocol
Connection mode	Bus type (Multi-drop method, T-branch method, Tree branch method)
Number of connection points*3	Number of bit points: 1024 points max. (Input: 512 bits, Output: 512 bits) Number of word points: 1024 words max. (Input: 512 words, Output: 512 words)
Number of connection units*3	Up to 256 units
RAS function	Detection of transmission line disconnection, transmission line short-circuit, transmission power supply drop, and duplicated/unregistered ID

- *3 The number differs depending on the master unit. Be sure to refer to the manual of the master unit for the number.

■ Individual specifications

Number of occupied points	BL296PB-08RS	Bit output: 8 points	
	BL296PB-08RSN	Bit output: 8 points	
Response time*4	1ms max.		
Detection function	Slave unit voltage drop (DP-DN voltage drop) I/O power supply drop (24V-0V voltage drop)		
Current consumption		Transmission side (DP-DN)	I/O side (24V-0V)
	BL296PB-08RS BL296PB-08RSN	6mA 6mA	200mA*5 6mA*6
Weight	BL296PB-08RS	365g	
	BL296PB-08RSN	205g	

- *4 Indicates the internal processing time of this unit. The maximum transmission delay time is defined as "this time + bit transmission cycle time x 2."
- *5 The value in case all points turn ON (including consumption current of relays).
- *6 The value in case all points turn ON without relays. Please include consumption current of relays on an as-needed basis.

[Outside Dimensions]

Unit: mm

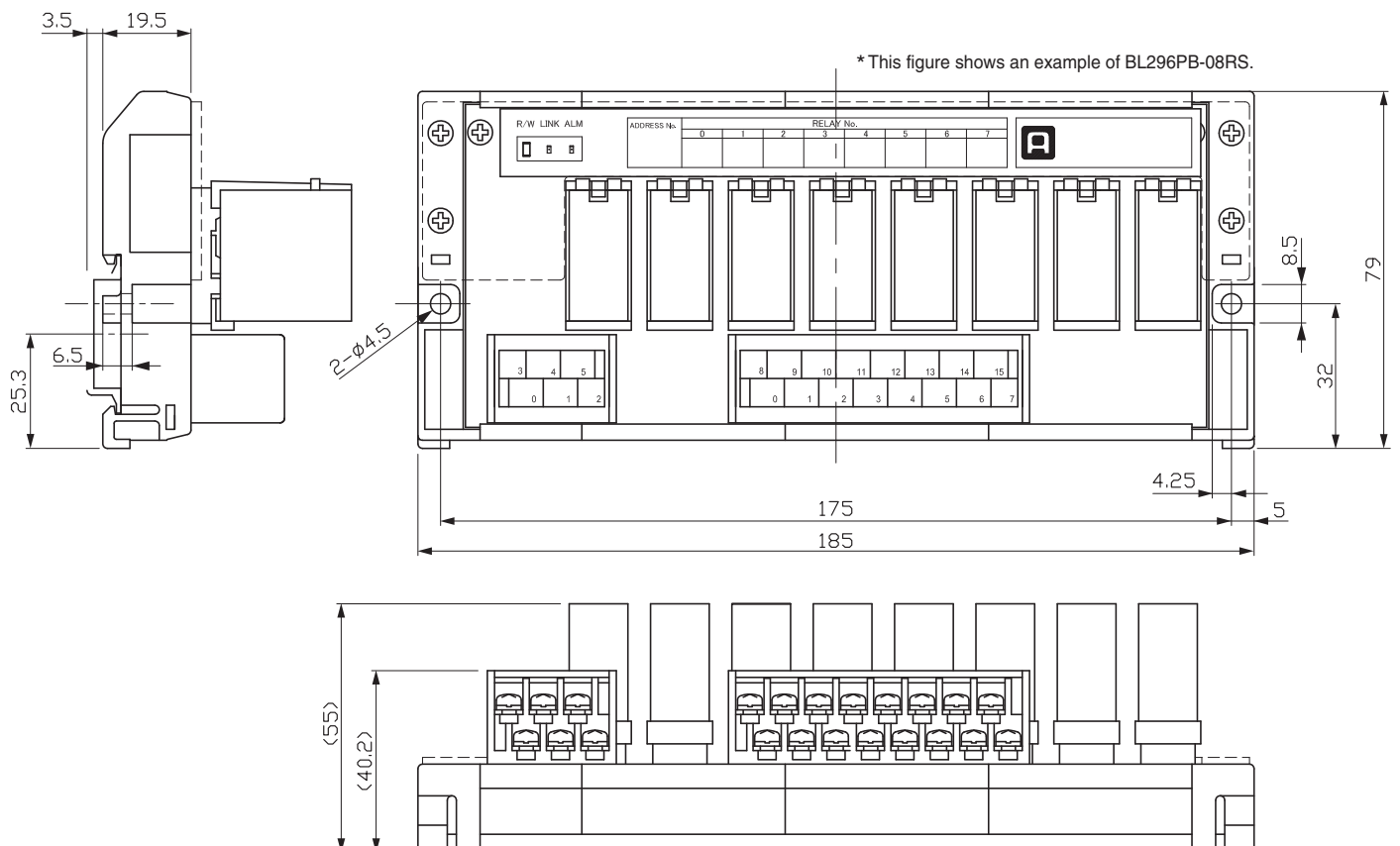

【中国版RoHS指令】

电子信息产品上所示标记是依据SJ/T11364-2006规定,按照电子信息产品污染控制标识要求制定。

本产品的环保使用期限为10年。如果遵守产品说明书中的操作条件使用电子信息产品,不会发生因产品中的有害物质泄漏或突发异变而引发严重的环境污染,人身事故,或损坏财产等情况。

的产品中有害物质的名称及含量

部件名称	有害物质					
	铅 (Pb)	汞 (Hg)	镉 (Cd)	六价铬 [Cr(VI)]	多溴联苯 (PBB)	多溴二苯醚 (PBDE)
安装基板	×	○	○	○	○	○
框架	○	○	○	○	○	○

本表格依据SJ/T11364的规定编制。
○:表示该有害物质在该部件所有均质材料中的含量均在GB/T26572规定的限量要求以下。
×:表示该有害物质至少在该部件的某一均质材料中的含量超出GB/T26572规定的限量要求。



基于中国标准法的参考规格:GB/T15969.2

[Address]

Anywire Anywire Corporation

Headquarters :1 Babazusho, Nagaokakyo-shi, Kyoto 617-8550 JAPAN

Contact :Contact by mail info_e@anywire.jp
:Contact by website http://www.anywire.jp

Printed in Japan 2014,2017,2019,2020,2022 UMA-10023AH-EN