

AnyWireASLINK System Products Guide

ASLINKTERMINAL [ASLINK Terminal (Driver type)]

BL264PB-16F□-T5 (Applicable to CKD product)

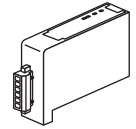

This Products Guide is a document that describes individual products. Read it carefully to understand the products.

■ Function list

Model	Specifications	Connection targets	Functions				
			Detection of remote unit voltage drop	Detection of sensing level drop	Detection of I/O disconnection	Detection of I/O short-circuit	Detection of I/O power supply drop
ASLINKTERMINAL 4-wire (isolated) Manifold driver	NPN output: 16 points PNP output: 16 points	CKD manifold MN4G					
			○	×	×	×	○

■ Note on use ⇒ A separate Address Writer is required to set addresses and other data.

* For more information, refer to [Various Settings] on page 6.

[Notes on Safety]

Precautions that must be observed in order to use this system safely are indicated as shown below. You must observe these precautions.



A WARNING indicates a potentially hazardous situation which, if not handled correctly, could result in death or serious injury.



A CAUTION indicates a potentially hazardous situation which, if not handled correctly, may result in personal injury or property damage.



- System Safety
This system is intended for general industrial applications. It does not have functions for supporting applications requiring higher levels of safety such as safety-related devices or accident prevention systems. The product must not be used for these purposes.
- Always turn off the power in installing or replacing the system.
- Prolonged continuous flow of a rated load current or higher or a transit current due to load short-circuit, etc., in the hybrid unit including the output unit and the output circuit may result in smoking or firing. An external safety device such as a fuse must be installed.



- System power supply
Use a stable, 24V DC power supply. Use of an unstable power supply may cause problems with the system.
- Separately route high-voltage and power cables
Although the AnyWireASLINK has a high noise margin, install the transmission line and I/O cables away from high-voltage and power cables.
- Connectors and terminals
 - Pay careful attention to the length and installation of cable wiring to ensure that connectors and cables are neither overloaded nor disconnected.
 - Make sure to prevent any metal objects from getting inside the connectors or the terminal blocks.
 - Short-circuits caused by metal objects or mis-wiring are likely to damage the device.
- Do not impose any external loads on the units. Doing so may cause a failure.
- Do not disconnect or reconnect between the transmission line and remote units when the transmission line is active. A malfunction may occur.
- Use the AnyWireASLINK within the range of the specifications and conditions shown below.

[Warranty]

■ Warranty period

The warranty period of the delivered product shall be one year after delivery to the place specified by the customer.

■ Scope of warranty

If a fault occurs with the product under the normal operating conditions assumed in the product specifications and according to the instructions of this manual within the above warranty period, faulty parts shall be replaced or repaired free of charge.

Note: The following cases are exempted from the scope of warranty:

- (1) User's improper handling or use of the product
- (2) When the fault is caused by any factor other than the delivered product
- (3) When the fault is caused by modification or repair of the product by any person other than the supplier
- (4) When the fault is caused by a natural disaster or other factor which is not attributable to the supplier

The term "Warranty" mentioned here means warranty of the delivered product only. We shall not be liable for incidental damage resulting from a fault of the delivered product.

■ Repair at user's cost

Investigations and repairs after elapse of the warranty period shall be conducted at user's cost.

Even in the warranty period, we shall accept order of repair of a fault or investigation of a cause of a fault beyond the above scope of warranty at user's cost.

■ Changes in the manual

The descriptions in this manual may be subject to change without notice.

[Type]

BL264PB-16F-T5	NPN output	16 points
BL264PB-16FS-T5	PNP output	16 points

Applicable to MN4G-T70-FL series manifold
manufactured by CKD Corporation

[How to Connect AnyWireASLINK]

The AnyWireASLINK can employ a two-wire or four-wire terminal selectively depending on the load current. If the load current is small, using a two-wire (non-isolated) terminal allows for achieving simplified wiring without local power supply. In the case of prioritizing the sites of concentrated loads and/or the number of connections, hybridization with a four-wire (isolated) terminal, which supports local power supply, is also possible. Make sure to use a four-wire (isolated) terminal in the case of input and load driving using an external power supply.

[System Configuration Example]

Relationship between the size and length of the transmission line and the supply current (Table 1)

Size of the transmission line (DP, DN)	Supply current on the transmission line (DP, DN)		
	Total length: 50m or less	Total length: Over 50m, no longer than 100m	Total length: Over 100m, no longer than 200m
1.25mm ²	MAX 2A	MAX 1A	MAX 0.5A
0.75mm ²	MAX 1.2A	MAX 0.6A	MAX 0.3A
0.5mm ²	MAX 0.8A	MAX 0.4A	MAX 0.2A

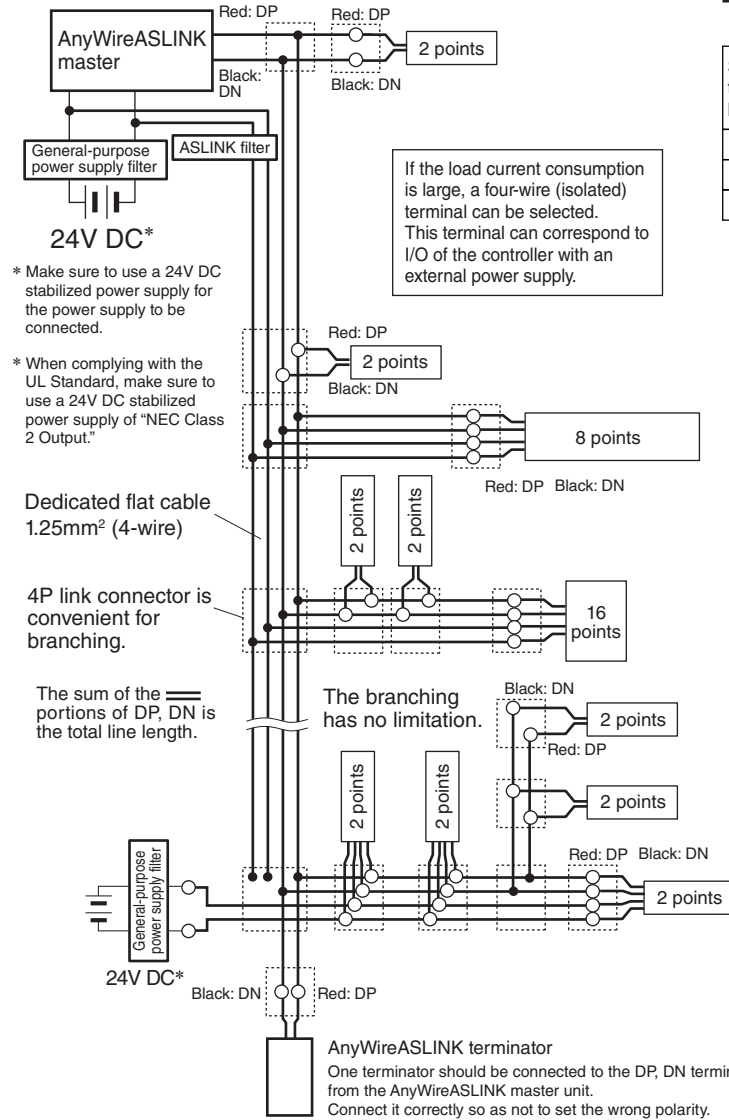

CAUTION

- Refer to Table 1 so that the size and length of the transmission line and the allowable supply current lie within an appropriate range.
- Connect the same symbols (DP, DN) correctly between the AnyWireASLINK master unit and each device.
- The branching length or branch number has no limitation.
- Include the length of the cable provided with the terminal in the "total line length."
- Connect the terminator (with polarity) to the transmission line terminal farthest from the AnyWireASLINK master unit.

[Installation Location]

- Locations where this product is not directly subject to vibration or shock
- Locations where this product is not directly exposed to dust
- Locations where this product is not directly exposed to conductors, such as metal chips or spatters
- Locations without condensation
- Locations where the atmosphere is free of corrosive gases, flammable gases, and sulfur
- Locations far from high-voltage or high-current cables
- Locations far from servos, inverters, and other cables and controllers that generate high-frequency noise

[Notes on Use of 4-Wire (Isolated) Terminal]

If the total length of the sections where all the DP, DN, 24V, and 0V lines run in parallel in the power supply system is more than 50m, connect an ASLINK filter (Type ANF-01) or a filter manufactured by COSEL Co., Ltd. (Type EAC-06-472) in series to the 24V and 0V lines at a position where these four lines start running in parallel.

This will improve noise resistance, suppress the adverse effects of crosstalk caused by transmitted signals, and stabilize signals.

The above filters must be inserted regardless of whether power is supplied to all terminals collectively from the power supply for the master or power is supplied to each terminal individually from their local power supply.

Insert the "ASLINK filter [Type ANF-01]" regardless of installation method and distance when complying with CE Standard.

Filter allowable current

Product	Type	Allowable power current
ASLINK filter	ANF-01	MAX 5A/24V DC
Filter of COSEL Co., Ltd.	EAC-06-472	MAX 6A/24V DC

AnyWire Type: ANF-01 Connection example

① Power supply to the entire system

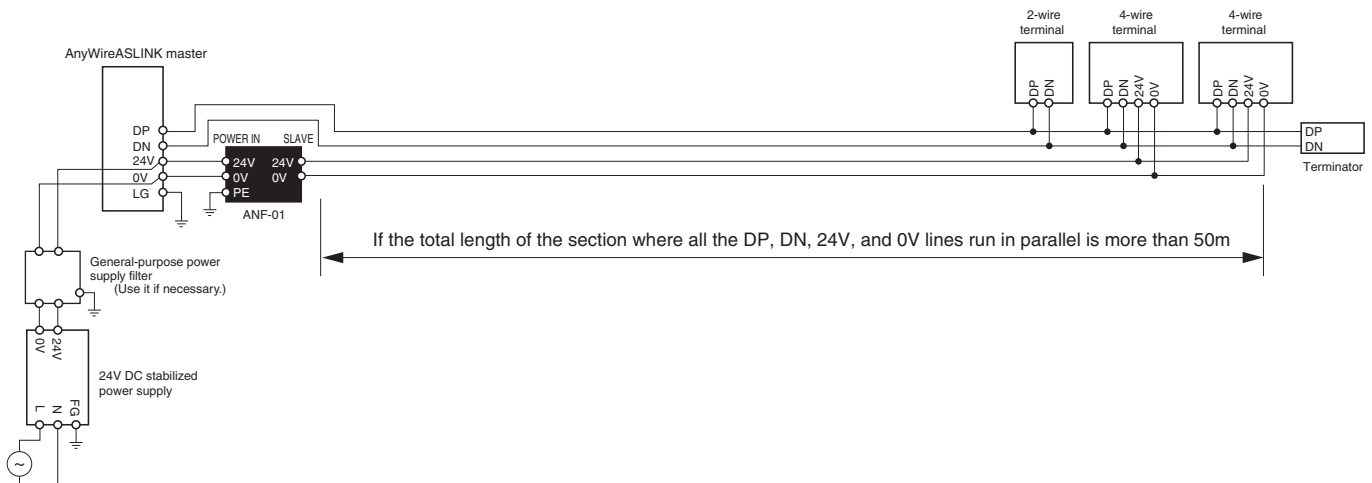

② Local power supply/branching

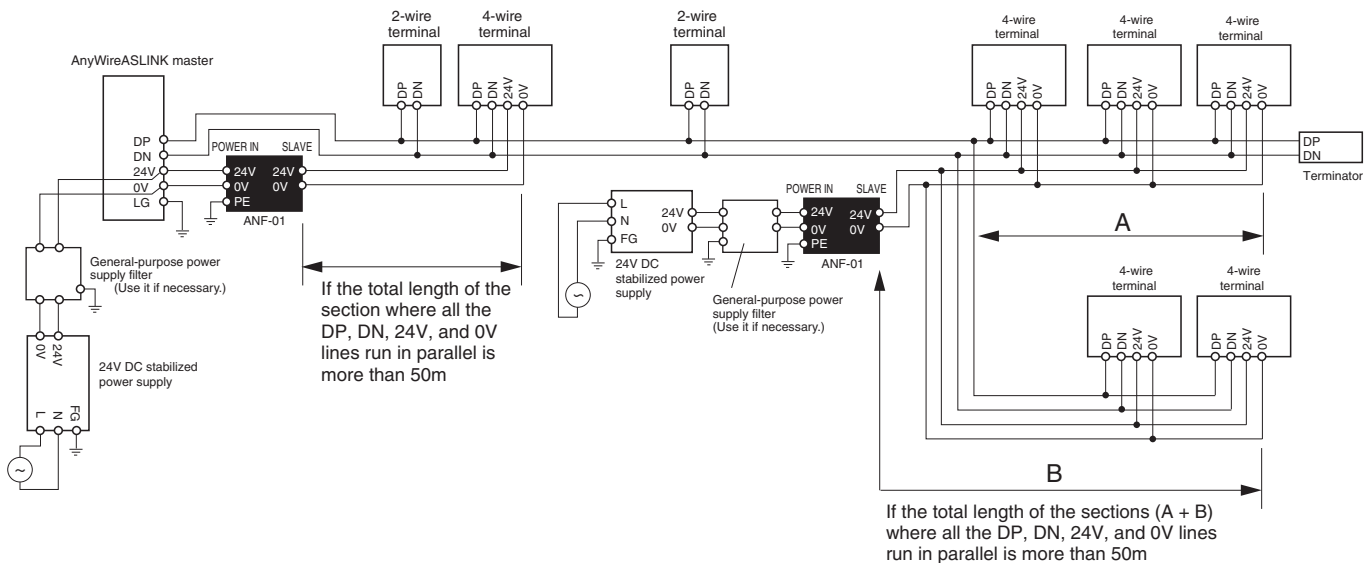

① Power supply to the entire system

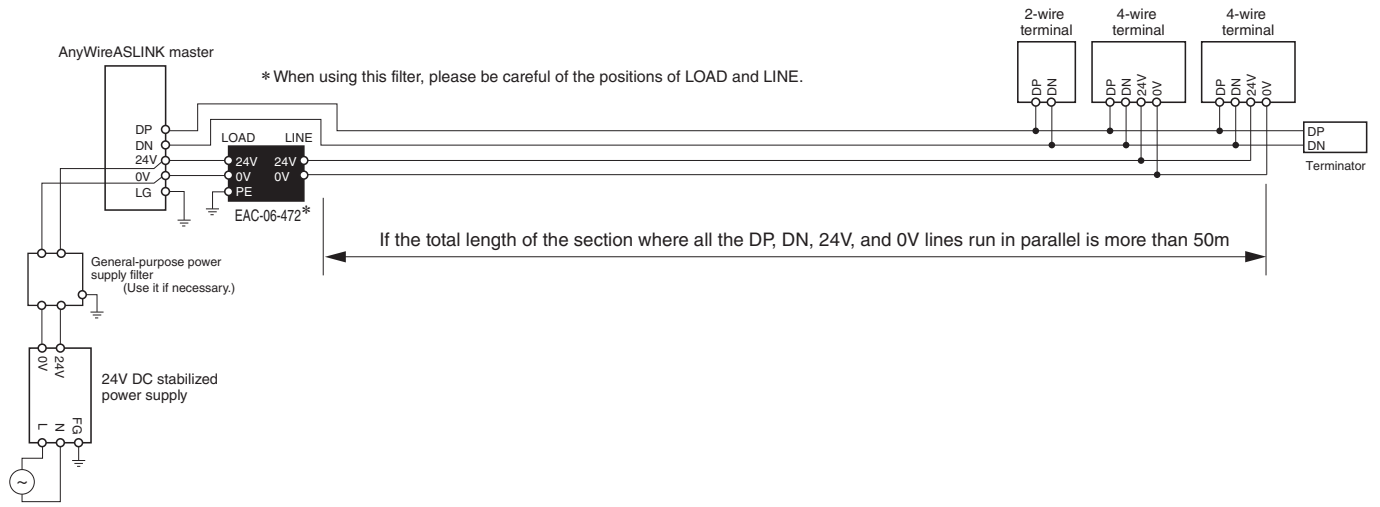

② Local power supply/branching

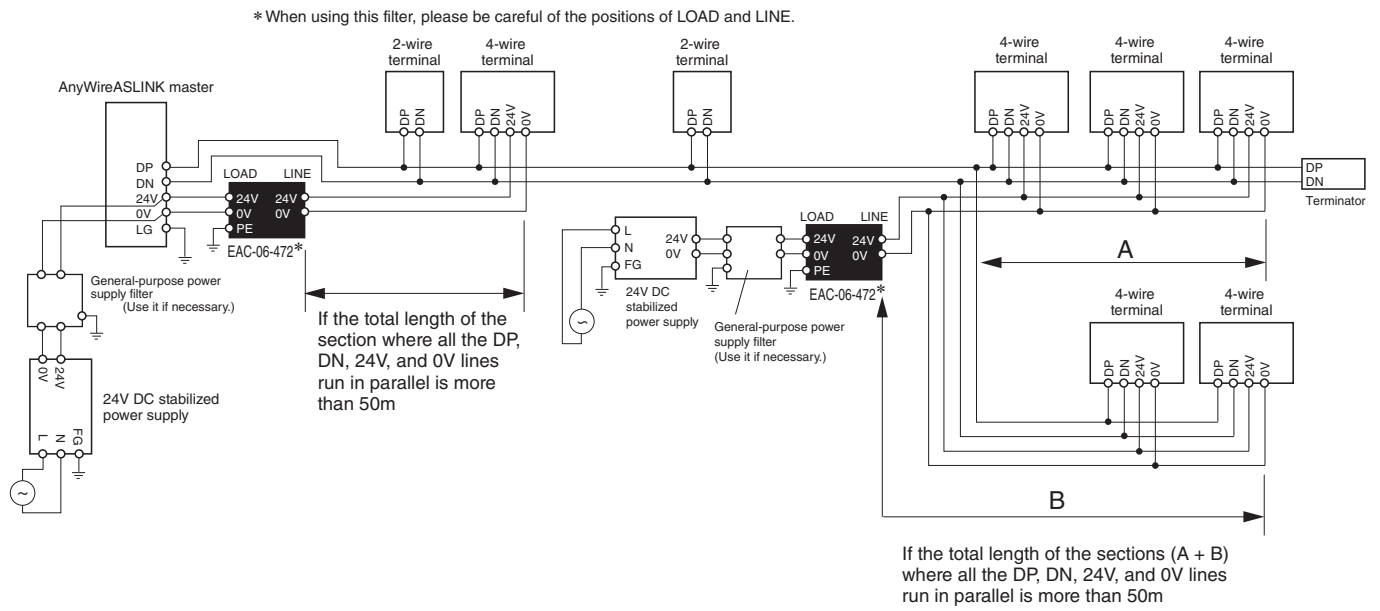

[Name of Each Part]

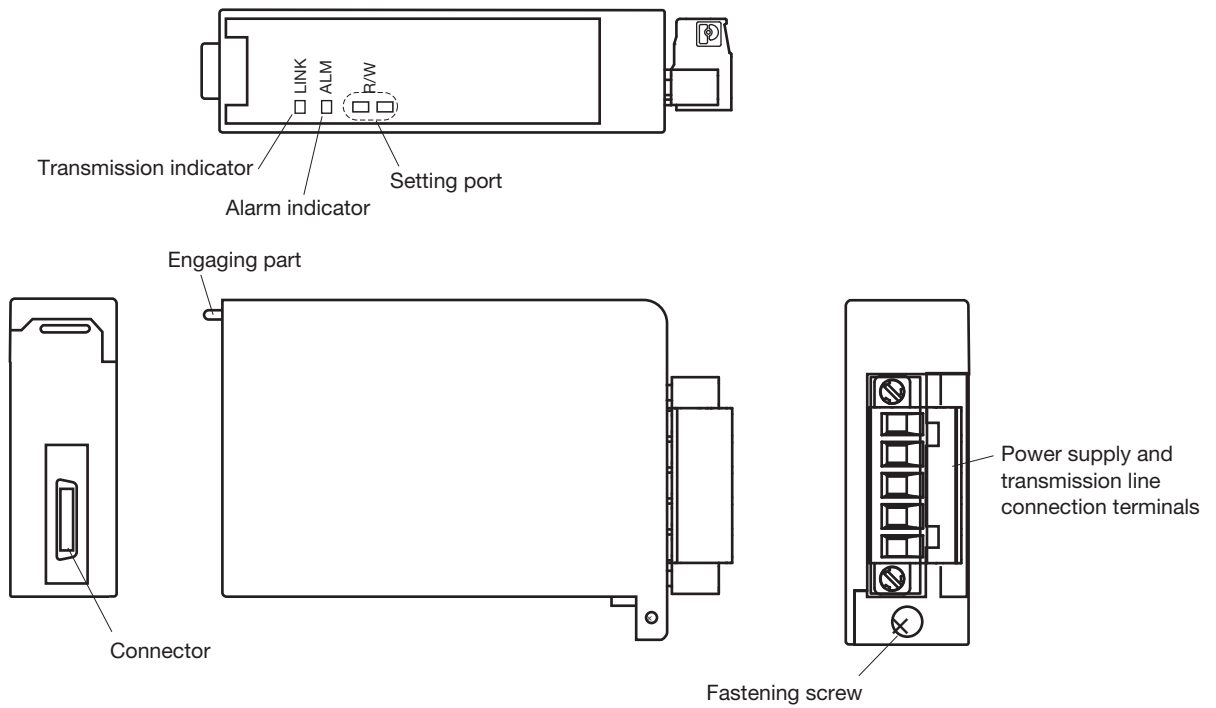

[Connecting Parts]

The terminals to connect power supply and transmission line are plug-in type. Connect each terminal correctly according to the terminal layout. For connections, refer to the example given on page 3.

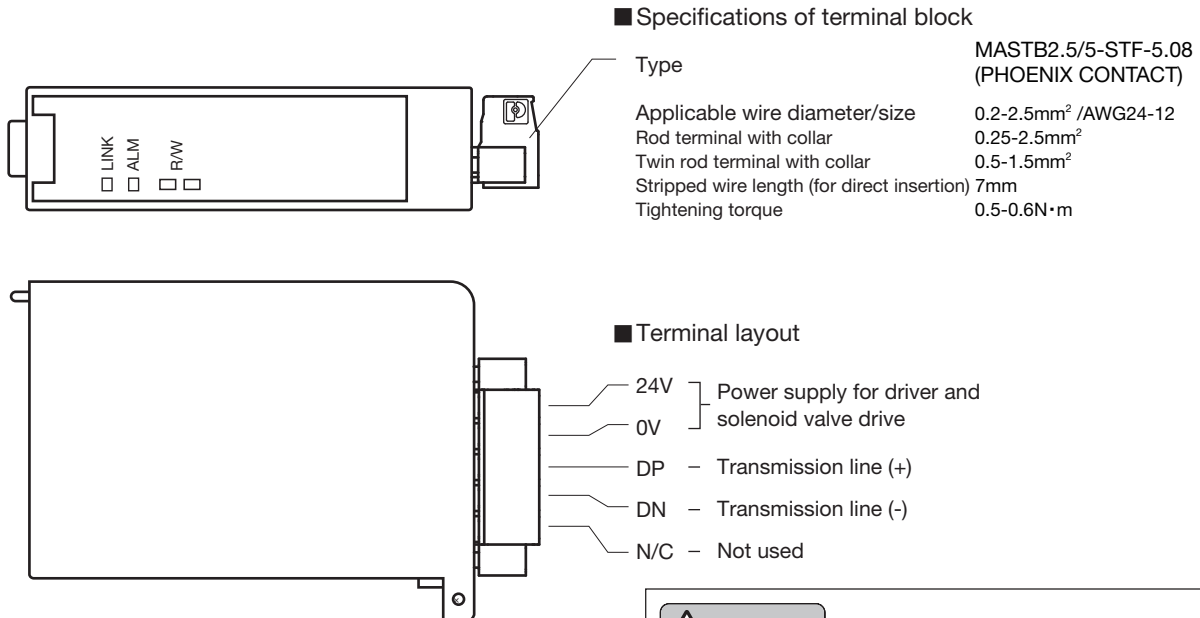

CAUTION

When you dismount the terminal block, make sure that the retaining screw has come off the socket, and then pull out the terminal block straight.
If you pull out the terminal block with the screw inserted, or if you obliquely pry up the terminal block, it may cause a fault of the equipment.

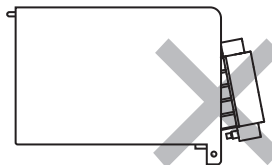

[Various Settings]

Address setting

■ Common procedure for address writer operation

Be sure to connect to the AnyWireASLINK master unit to use.
ARW-04 (address writer) of Rev. (Ver.) 1.01 or later version, or ARW-03 of Rev. (Ver.) 2.10 or later version is required for address setting.
For details of the operating method, refer to the product guide of the address writer.

Connect this unit to the AnyWireASLINK master unit.
Set an address with the address writer with the transmission signal (DP/DN) and power supply (24V/0V) being connected.

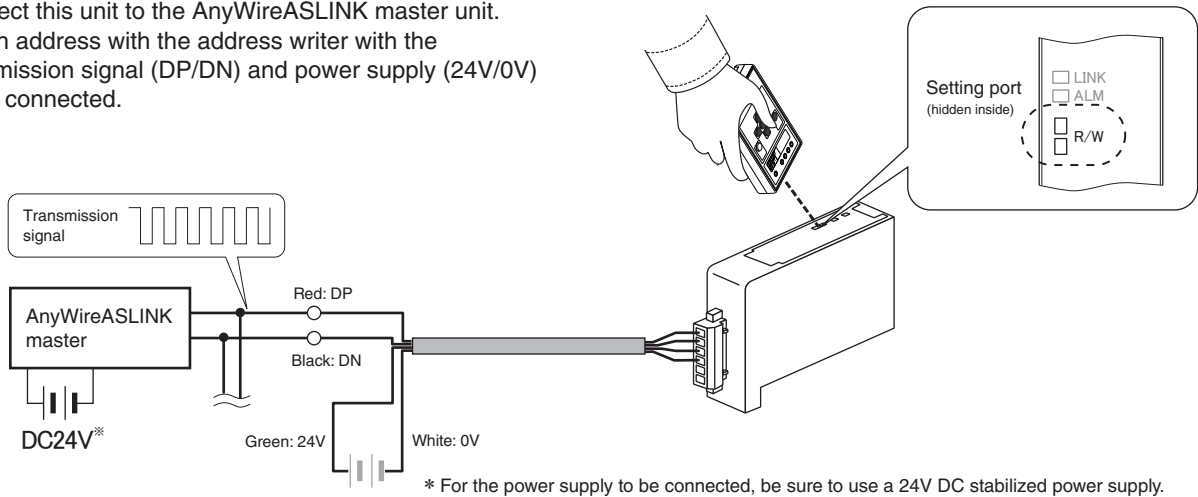

Address setting









An address number is set as a beginning number from which part of the transmission frame is occupied to the terminal.
Set the address number within the range of bit address "0 to 254."

- Set the address number so that the area occupied by the terminal does not exceed the transmission points of the master unit.
- Make sure that the address number setting is not duplicated.
- Also, use the address writer to read an address number that has been written in the terminal.



"Bit address 255" has been set for address number before shipment, which indicates that the terminal has not undergone address setting.
With the factory-set address, I/O operations are disabled.

[Monitor Display]

LED name	Display status	Description
LINK (Green)	Lit 	No transmission waveform
	Flashing 	Normal
	Unlit 	DP, DN line disconnection, no power
ALM (Red)	Lit 	I/O power supply drop
	Flashing 	Remote unit voltage drop
	Unlit 	Normal
LINK ALM	Alternate flashing LINK  ALM 	The master unit has detected that the unit ID (address) is either duplicated or unregistered

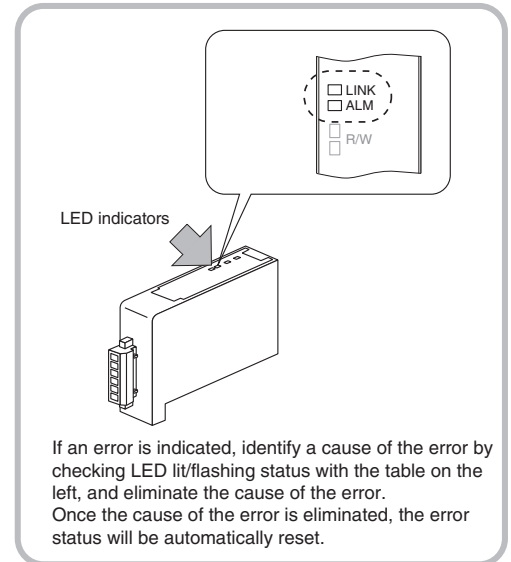

[Troubleshooting]

<LINK does not flash>

Things to be checked	Remedy
Check the connection of remote units.	Disconnect remote units and then reconnect them.
Check the connection of the master unit.	Check to see if the LINK LED on the master unit is flashing and take the following actions. <ol style="list-style-type: none"> 1) If LINK on the master unit is flashing and LINK on the remote unit is lit, there is a possibility that the master unit is damaged. Contact the customer support. 2) If LINK on the master unit is flashing and LINK on the remote unit is unlit, it is possible that the power (24V DC) is not supplied to the master unit, there is a disconnection on the transmission line (DP, DN), or the remote unit has been damaged. Ensure that the power is supplied to the master unit and, if necessary, contact the customer support. 3) If LINK on the master unit is not flashing, check the power supply to the master unit. Also, since there is a possibility that some system error has occurred, refer to the user's manual of master unit.

<ALM is lit>

Things to be checked	Remedy
Check the connection of I/O terminals on the remote unit.	Adjust the voltage of external power supply connected to the I/O side of the remote unit so that it falls within the rating (21.6 to 27.6V). In addition, ensure that there is no contact between and erroneous wiring of transmission lines.

<ALM is flashing>

Things to be checked	Remedy
Check the voltage (24V DC) of external power supply to the master unit.	Adjust the voltage of external power supply to the master unit so that it will be in the range from 21.6 to 27.6V. (Recommended voltage is 26.4V.) Check the total length. Review the total length and wire diameter of transmission line so that the load will not exceed the current limit supplied by the transmission line and adjust the connected load. (In the case of the wire size of 1.25mm ² and total length of 50m or less, the current supplied by the transmission line is 2A.) If ALM is flashing although the appropriate voltage is applied to the 24V and 0V terminals of the master unit and this unit, it is possible that this unit has a fault. In this case, replace this unit.

<LINK and ALM flashes alternately>

Things to be checked	Remedy
Check the address of the remote unit.	The address of the remote unit is either unregistered (255) or duplicated. Take the following actions. <ol style="list-style-type: none"> 1) Change the address in the range of 0 to 254. 2) Check if there is a remote unit on which the indicator lamps are flashing in the same manner and reset the addresses so that they are not duplicated.

[Configuration and Electrical Characteristics of Output Circuit]

BL264PB-16F-T5: 4-wire (isolated) NPN output

<Circuit conditions>

Withstand voltage: 30V DC
Max. ON current: 100mA

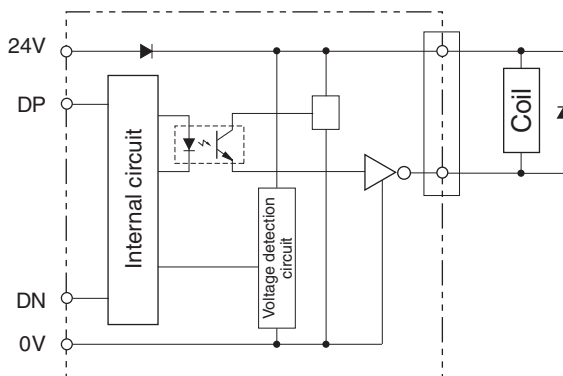

For connection of a solenoid valve, specify a type with a surge killer.

BL264PB-16FS-T5: 4-wire (isolated) PNP output

<Circuit conditions>

Withstand voltage: 30V DC
Max. ON current: 100mA

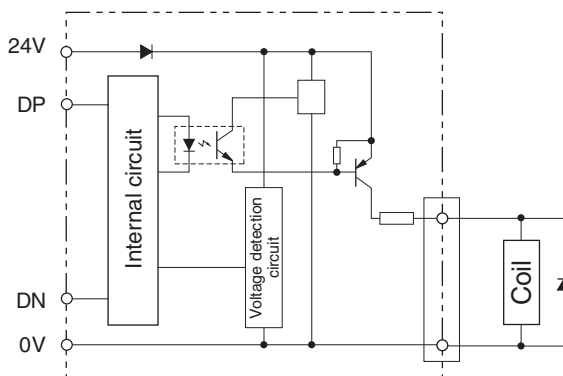

For connection of a solenoid valve, specify a type with a surge killer.

[Specifications]

■ General specifications

Operating ambient temperature/humidity	0 to +55°C, 30 to 85%RH No condensation
Storing ambient temperature/humidity	-20 to +70°C, 30 to 85%RH No condensation
Atmosphere	No corrosive gas
Operating altitude*1	0 to 2000m
Pollution level*2	2 or less

*1 Do not use or store AnyWireASLINK devices in an environment where the pressure exceeds the atmospheric pressure at an altitude of 0 meters. Doing so may result in malfunction.

*2 "Pollution level" is an index that indicates the degree of occurrence of conductive substances in the environment where the device is used.

Pollution level 2 means the occurrence of only pollution by non-conductive substances. In such an environment, however, electrical conduction could occur due to accidental condensation.

■ Transmission specifications

Service power supply voltage	24V DC +15% to -10% (21.6 to 27.6V DC) with a ripple of 0.5Vp-p or less
Transmission method	DC power supply superimposed total frame/cyclic method
Synchronization method	Frame/bit synchronization method
Transmission procedure	AnyWireASLINK protocol
Connection mode	Bus type (Multi-drop method, T-branch method, Tree branch method)
Number of connection points*3	512 max. (IN: 256, OUT: 256)
Number of connection units*3	Up to 256 units
RAS features	Detection of transmission line disconnection, transmission line short-circuit, transmission power supply drop, and duplicated/unregistered ID

*3 The number differs depending on the master unit. Be sure to refer to the manual of the master unit for the number.

■ Individual specifications

Number of occupied data items	BL264PB-16F-T5 NPN output: 16 points BL264PB-16FS-T5 PNP output: 16 points
Monitoring function	Remote unit voltage drop I/O power supply drop
Response time*4	1ms max.
Current consumption	Transmission side (DP-DN): 7mA I/O side*5 (24V-0V): 38mA
Weight	55g

*4 Apart from the transmission delay time (2-cycle time), the internal processing time required for the terminal to recognize a change in the signal.

*5 Current consumption for output is a value assumed when all points are turned ON. Add a total current consumption of load being connected.

[How to Mount This Unit to a Manifold]

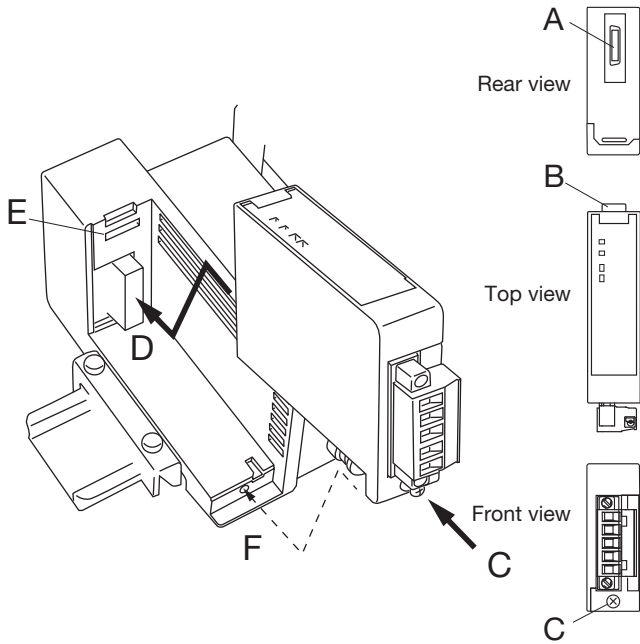

This manifold driver is intended for the MN4G-T70-FL series manifold manufactured by CKD Corporation. Mount the driver to the specified manifold. (Purchase the manifold separately.)
MN4G-T70-FL can be connected to a solenoid valve quickly with the plug-in connector.

■ Mounting procedure

Mount BL264PB-16F□-T5 to the driver mounting part of the manifold as shown on the left.

Thus, the connector (A) at the back of the driver is fit on the connector (D) of the manifold, and the engaging part (B) of the driver is engaged in the groove (E) of the manifold.

After confirming that BL264PB-16F□-T5 is normally mounted, insert the fastening screw (C) of the driver into the screw hole (F) of the manifold, to fasten the driver.

[Outside Dimensions]

Unit: mm

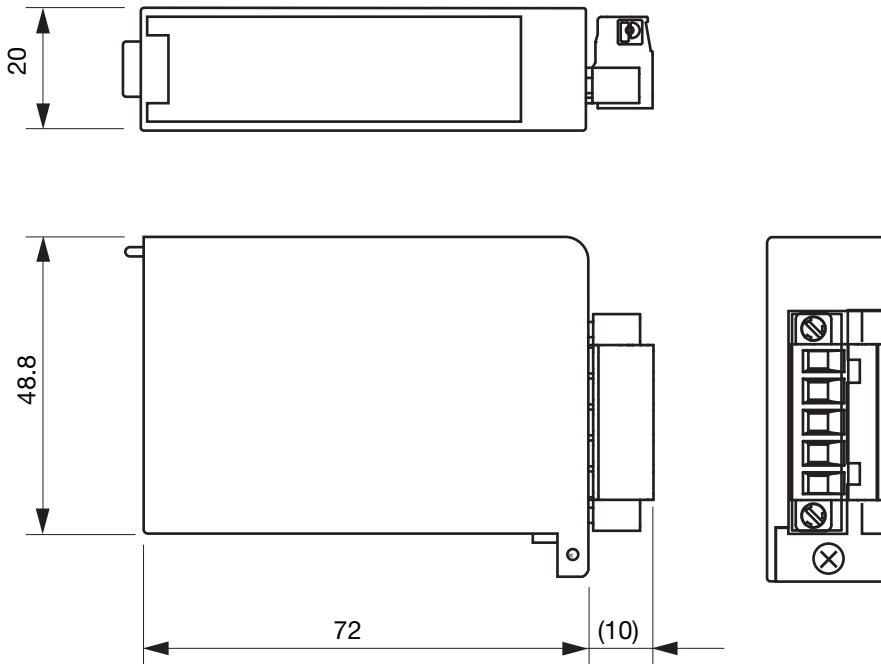

【中国版RoHS指令】

的产品中有害物质的名称及含量

部件名称	有害物质					
	铅 (Pb)	汞 (Hg)	镉 (Cd)	六价铬 [Cr (VI)]	多溴联苯 (PBB)	多溴二苯醚 (PBDE)
安装基板	×	○	○	○	○	○
框架	○	○	○	○	○	○

本表格依据 SJ/T11364 的规定编制。

○：表示该有害物质在该部件所有均质材料中的含量均在 GB/T26572 规定的限量要求以下。

×：表示该有害物质至少在该部件的某一均质材料中的含量超出 GB/T26572 规定的限量要求。



基于中国标准法的参考规格：GB/T15969.2

[Address]

Anywire Anywire Corporation

Headquarters :1 Babazusho, Nagaokakyo-shi, Kyoto 617-8550 JAPAN

Contact :Contact by mail info_e@anywire.jp
:Contact by website http://www.anywire.jp

Printed in Japan 2014,2017,2018,2023 UMA-09667AH-EN